

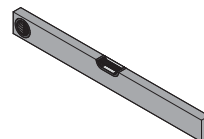

26858

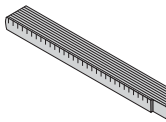

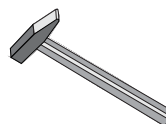

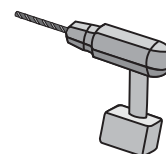
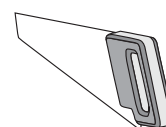

-  **Aufbauanleitung**
-  **Building Instructions**
-  **notice de montage**
-  **montagehandleiding**
-  **Montagevejledning**
-  **Instrucciones de construcción**
-  **Istruzioni per il montaggio**
-  **Montážní návod**











 Bitte bewahren Sie die Anleitung und den Garantieschein zur Seriennummer auf. Vernichten Sie diese erst nach Ablauf der Garantiezeit. Eventuelle Beanstandungen können mithilfe der Stückliste einfacher zugeordnet werden.





Beigelegte Dokumente:

- Informationsheft
- Garantieschein zur Seriennummer
- Typenschild inkl. Warnhinweise (Sauna)
- ggf. Zubehör-Anleitungen in externen Paketen

- *  Nicht im Lieferumfang enthalten
 Not included
 Non comprises dans la livraison
 Niet bijgeleverd



-  No forman parte del suministro
 Non incluso
 V ceně není zahrnuto
 Ikke inkluderet

- 1  Länge muss ermittelt und zugesägt werden
 Length must be determined and sawn
 La longueur doit être déterminée et sciée
 De lengte moet worden bepaald en worden gezaagd

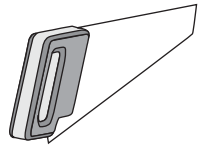
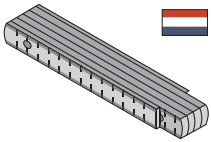
-  La longitud debe ser determinada y aserrada
 La lunghezza deve essere determinata e segata
 Délka musí být určena a rozřezána
 Længden skal bestemmes og saves



- 2  Nicht gebraucht
 Not needed
 Pas nécessaire
 Niet nodig



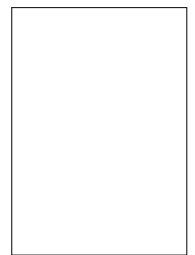

-  No es necesario
 Non necessario
 Není nutná

- 3  mit Zubehör!
 met toebehoren!
 with accessories!
 avec accessoires!



-  con accesorios!
 con accessori!
 s příslušenstvím!
 z dodatki!



- 4  Fixiert vorübergehend
 tijdelijk vast
 Fixed temporarily
 temporairement fixe

-  temporalmente fijo
 temporaneamente fisso
 dočasně pevný
 Zčasno pritrjeno

- 5  Bestand vom Haus
 Inventaris van het huis
 Inventory of the house
 Inventaire de la maison

-  Inventario de la casa
 Inventario della casa
 Inventář domu
 Inventar hiše

Werkzeuge / Tools*

X

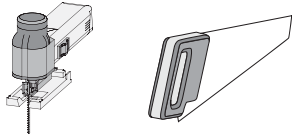

X

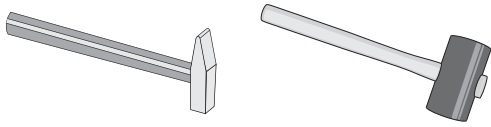

X

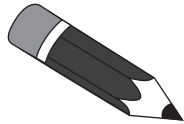

X

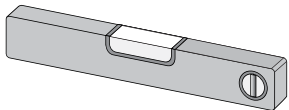

X

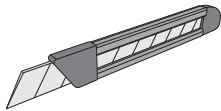

X

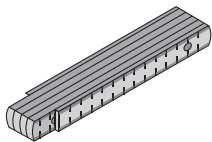

X

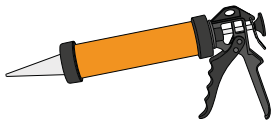

X

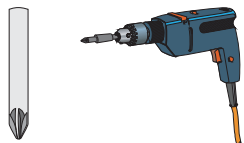

X

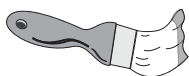
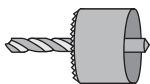
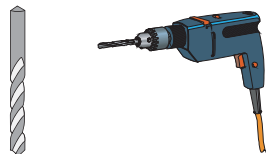

X



Technische Daten

In der Auftragsbestätigung bzw. Lieferschein ist der gekaufte Ofentyp bzw. das erworbene Steuergerät zu finden. Bitte entnehmen Sie die technischen Daten Ihrer Geräte der folgenden Auflistung

Gerät	Netzspannung	Wattage
Öfen		
9kW Ofen Bio	400V ~ 3N	9kW
9kW Ofen (Finnisch)	400V ~ 3N	9kW
9kW Ofen integr. Steuerung	400V ~ 3N	9kW
4,5kW Ofen Bio	400V ~ 3N	4,5kW
4,5kW Ofen (Finnisch)	400V ~ 3N	4,5kW
4,5kW Ofen integr. Steuerung	400V ~ 3N	4,5kW
3,6kW Ofen Bio	230V ~ 1N	3,6kW
3,6kW Ofen (Finnisch)	230V ~ 1N	3,6kW
3,6kW Ofen integr. Steuerung	230V ~ 1N	3,6kW
Steuergeräte		
externe Steuerung Easy Bio	400V ~ 3N	max. 10,8kW
externe Steuerung Plug&Play Bio	240V ~ 3N	max. 10,8kW
externe Steuerung (Finnisch)	400V ~ 3N	max. 10,8kW
externe Steuerung Plug&Play (Finnisch)	240V ~ 3N	max. 10,8kW
Multisteuergerät	400V ~ 3N	max. 10,5kW
externe Steuerung Classic Bio	400V ~ 3N	max. 9kW
externe Steuerung Classic (Finnisch)	400V ~ 3N	max. 9kW
externe Steuerung Premium Bio	400V ~ 3N	max. 12kW
externe Steuerung Premium (Finnisch)	400V ~ 3N	max. 9kW



Vergleichen Sie zuerst die Material-liste mit Ihrem Paketinhalt! Bitte haben Sie Verständnis, dass Beanstandungen nur im nicht aufgebauten Zustand bearbeitet werden können!



Vergelijk eerst de lijst van materialen met de inhoud van uw pakket! Reclamaties kunnen alleen in behandeling worden genomen zolang de onderdelen nog niet zijn gemonteerd!



Confrontate questa distinta materiali prima con il contenuto del pacchetto! Vi preghiamo di comprendere che eventuali reclami possono essere accolti solo prima del montaggio!



First compare the list of materials with your package contents! Please understand that complaints can be processed in the non-built status only!



Start med at kontrollere materialelisten med indholdet af den leverede pakke! Vi gør venligst opmærksom på at reklamationer kun kan behandles for materialer som ikke er blevet bearbejdet!



Nejprve přezkontrolujte obsah balení podle materiálového listu! Mějte pochopení pro to, že případnou reklamaci se můžeme zabývat pouze tehdy, když díly nebudou smontované! Za pomoci tohoto seznamu můžete jednotlivé díly přiřadit k montážnímu návodu.



Commencez par comparer la liste du matériel avec le contenu de votre paquet! Sachez que nous traitons uniquement les réclamations concernant le matériel à l'état non monté!



En primer lugar, compare la lista de material con el contenido del paquete. Rogamos entienda que las reclamaciones sólo pueden ser tramitadas antes de montar el objeto!

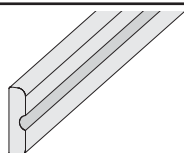
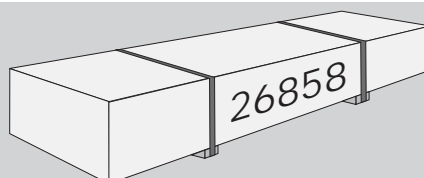

1 x A1	1127 x	90 x	22 mm	ID 85704
1 x A2	1745 x	90 x	22 mm	ID 26155
1 x A3	2243 x	90 x	22 mm	ID 26119

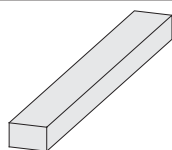

1 x B1	600 x	78 x	17 mm	ID 48532
1 x B2	900 x	78 x	17 mm	ID 48531
1 x B3	1000 x	78 x	17 mm	ID 48528
1 x B4	1200 x	78 x	17 mm	ID 48527
1 x B5	1800 x	78 x	17 mm	ID 48524
1 x B6	1100 x	45 x	18 mm	ID 21085
1 x B7	1675 x	45 x	18 mm	ID 21086
1 x B8	300 x	95 x	18 mm	ID 19130
2 x B9	60 x	38 x	28 mm	ID 20928
1 x B10	500 x	38 x	28 mm	ID 47817
2 x B11	625 x	38 x	28 mm	ID 42302
2 x B12	1120 x	38 x	28 mm	ID 26146
1 x B13	1156 x	38 x	28 mm	ID 20693
1 x B14	1731 x	38 x	28 mm	ID 20698
1 x B15	2191 x	38 x	28 mm	ID 20700

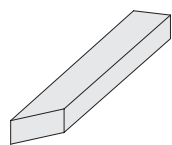

1 x C1	654 x	38 x	28 mm	ID 20689
1 x C2	973 x	38 x	28 mm	ID 21782

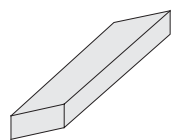

1 x C3	814 x	38 x	28 mm	ID 20692
--------	-------	------	-------	----------

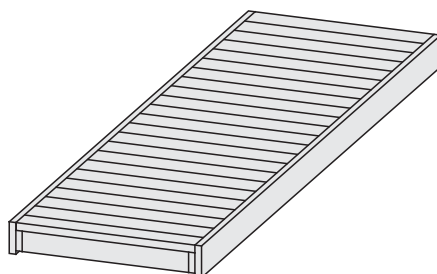

1 x L1	1127 x	500 x	95 mm	ID 85619
1 x L2	2243 x	550 x	95 mm	ID 52063
1 x L3	2243 x	600 x	95 mm	ID 85595

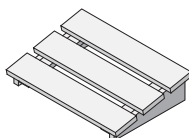

1 x L4				ID 20708
--------	--	--	--	----------

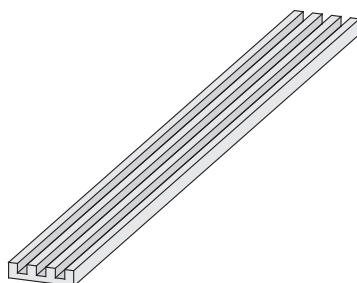

1 x E1	1820 x	140 x	26 mm	ID 26480
--------	--------	-------	-------	----------

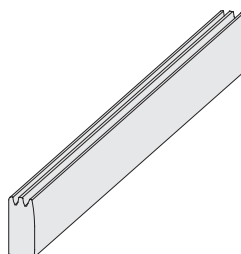

2 x H1	815 x	84 x	38 mm	ID 20635
--------	-------	------	-------	----------

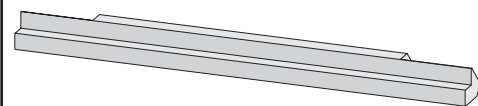

1 x Y1	2040 x	61 x	38 mm	ID 20701
--------	--------	------	-------	----------

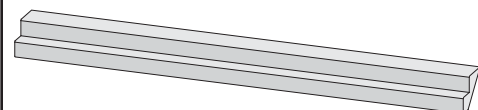

1 x Y2	2040 x	61 x	38 mm	ID 20702
--------	--------	------	-------	----------

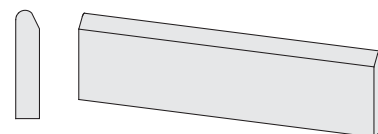

6 x G1	2085 x	78 x	17 mm	ID 48525
2 x G2	2085 x	95 x	17 mm	ID 48535



1 x N1	1727 x	904 x	68 mm	ID 56972
--------	--------	-------	-------	----------

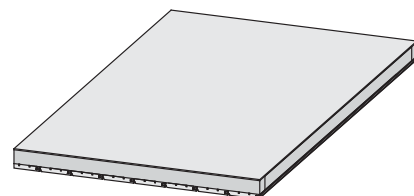

1 x N2	1152 x	681 x	57 mm	ID 43922
1 x N3	1727 x	658 x	57 mm	ID 43923



1 x W1 | 2040 x 689 x 40 mm | ID 20723

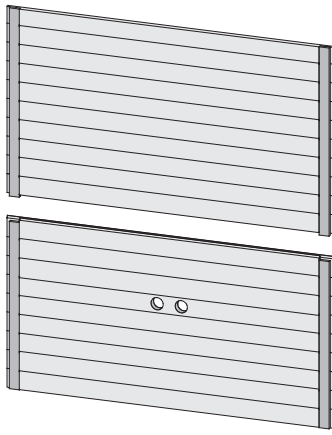

1 x W3 | 2040 x 2324 x 40 mm | ID 20820

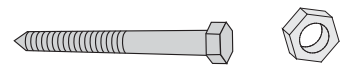

3 x | ID 14018

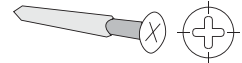

10 x | 4 x 30 mm | ID 3686

100 x | 4 x 50 mm | ID 3688

50 x | 4 x 70 mm | ID 3689

35 x | 6 x 60 mm | ID 14014

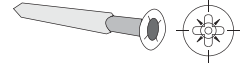

70 x | 4,5 x 40 mm | ID 26285

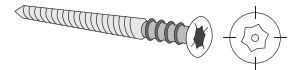

6 x | 6 x 80 mm | ID 14266



70 x | 4,5 x 30 mm | ID 26116

6 x | 12 x 18 mm | ID 46403

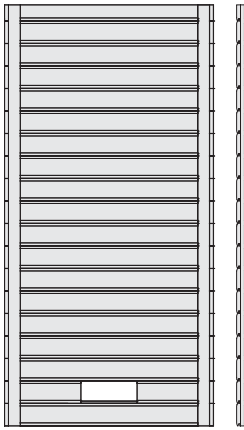

1 x W2 | 2040 x 1023 x 40 mm | ID 26865

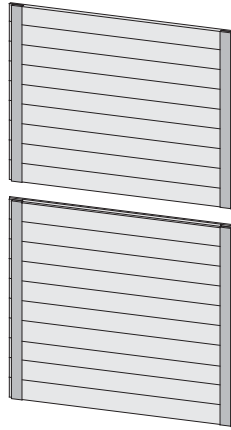

1 x W4 | 2040 x 1195 x 40 mm | ID 20717

1 x W5 | 2040 x 1770 x 40 mm | ID 20719

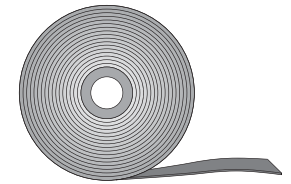

1 x | 10 mm | ID 14025

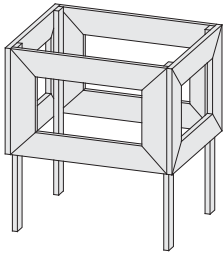

1 x | ID 27490

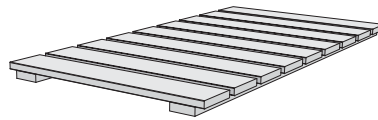

1 x | ID 72733

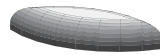

8 x | ID 26118

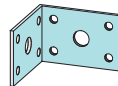

2 x | ID 21292

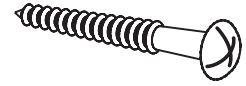

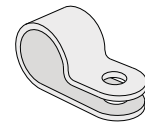

6 x | 3 x 16mm | ID 46376



1 x | ID 50420

 Übersicht
 Overview
 enquête

 overzicht
 undersøgelse
 estudio

 sondaggio
 přehled

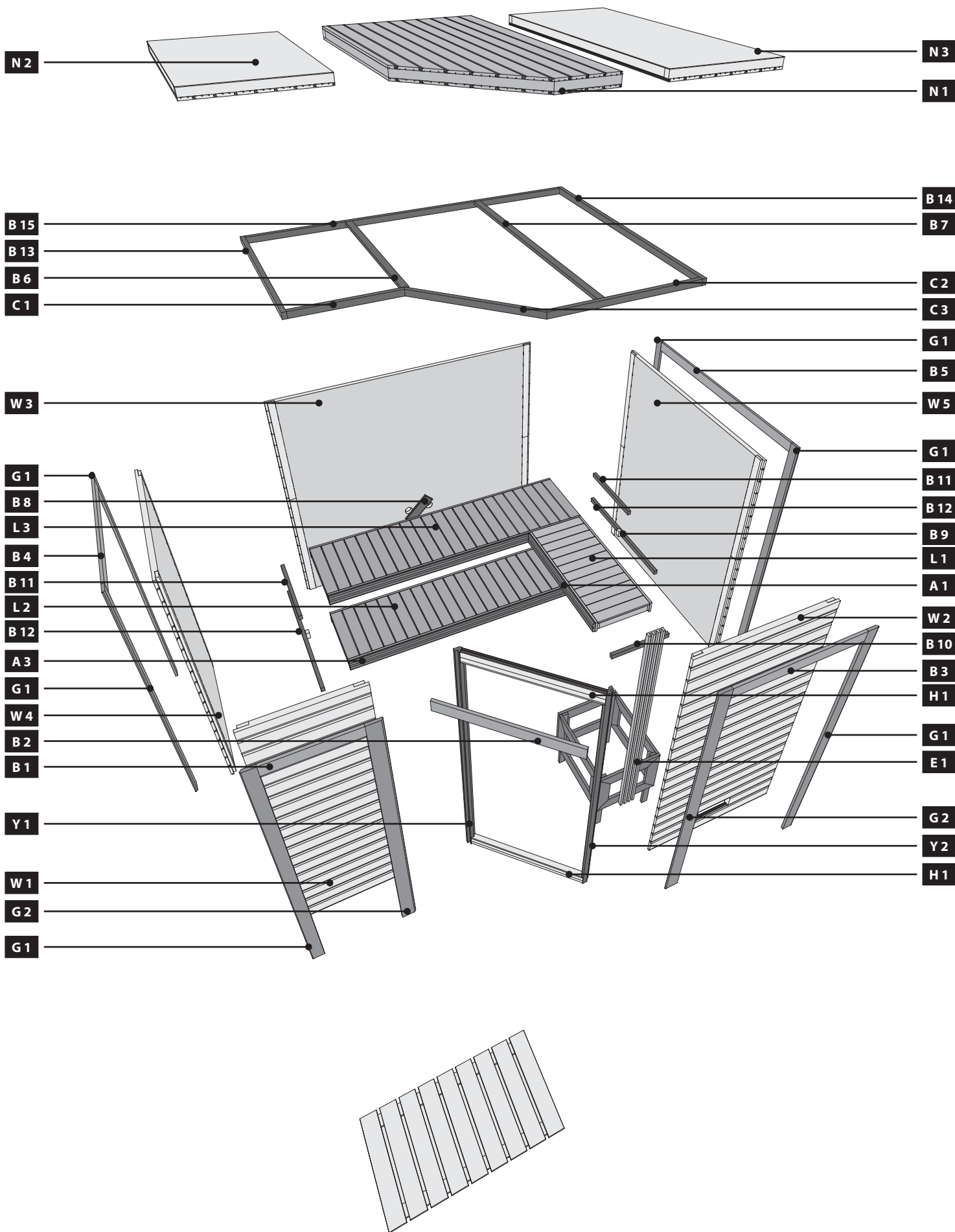

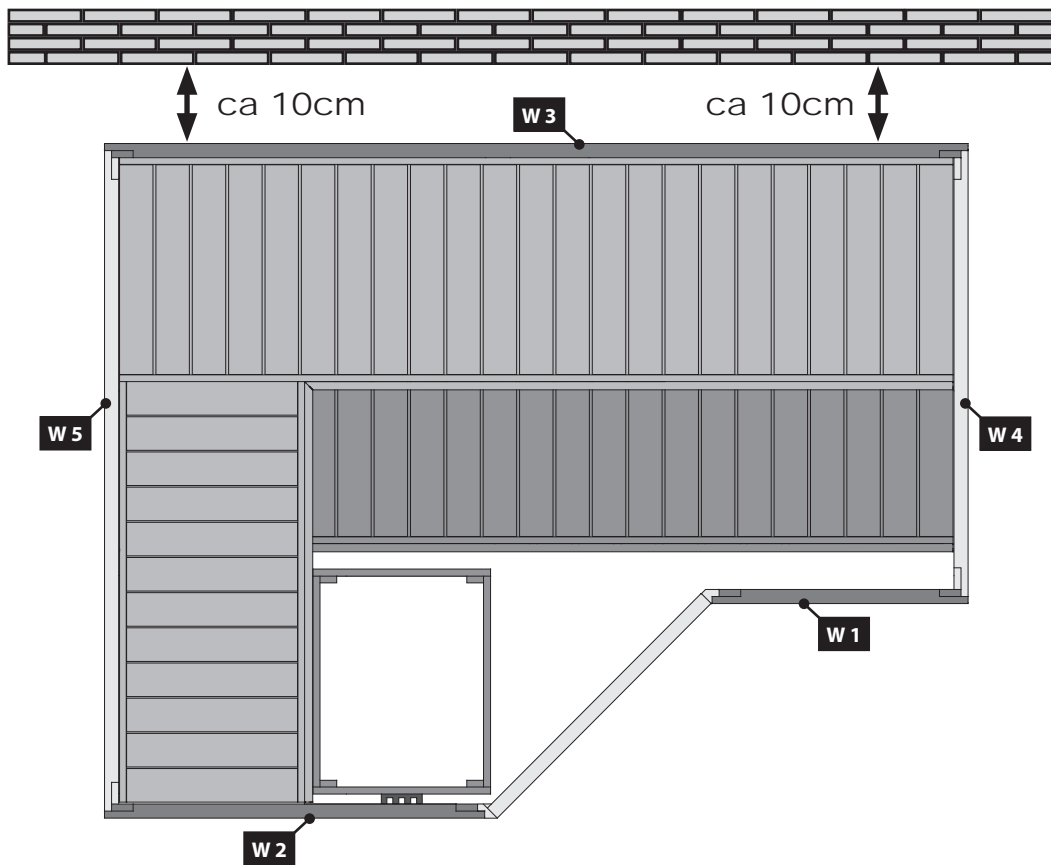
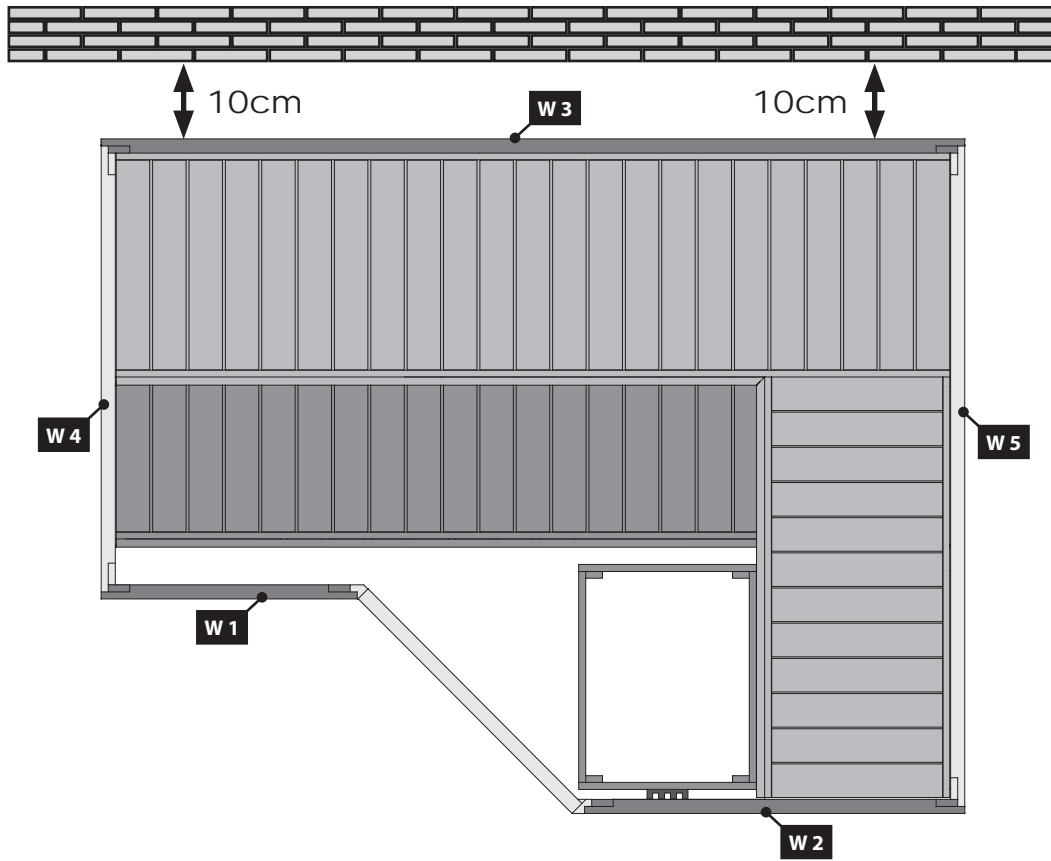

01

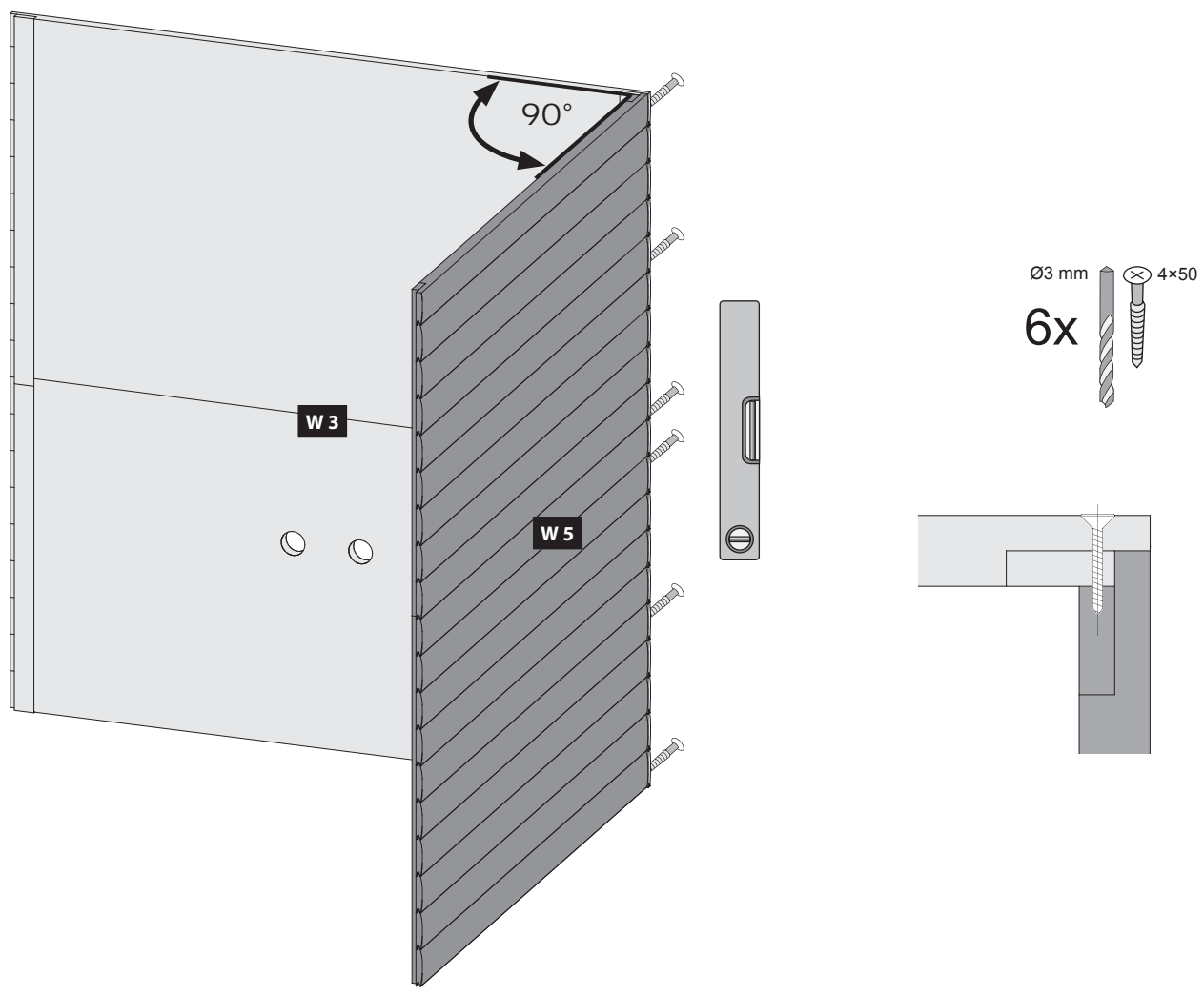

02

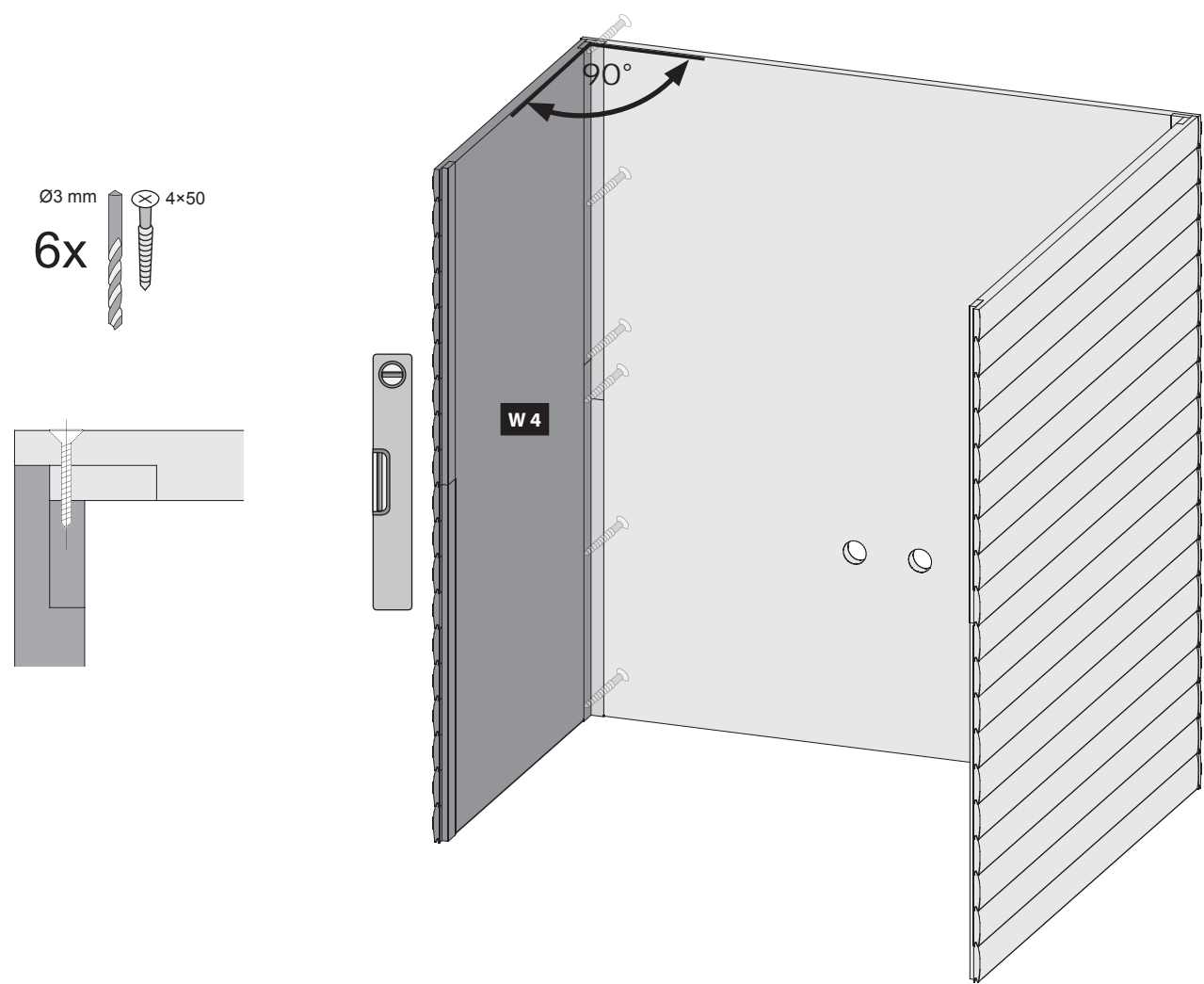

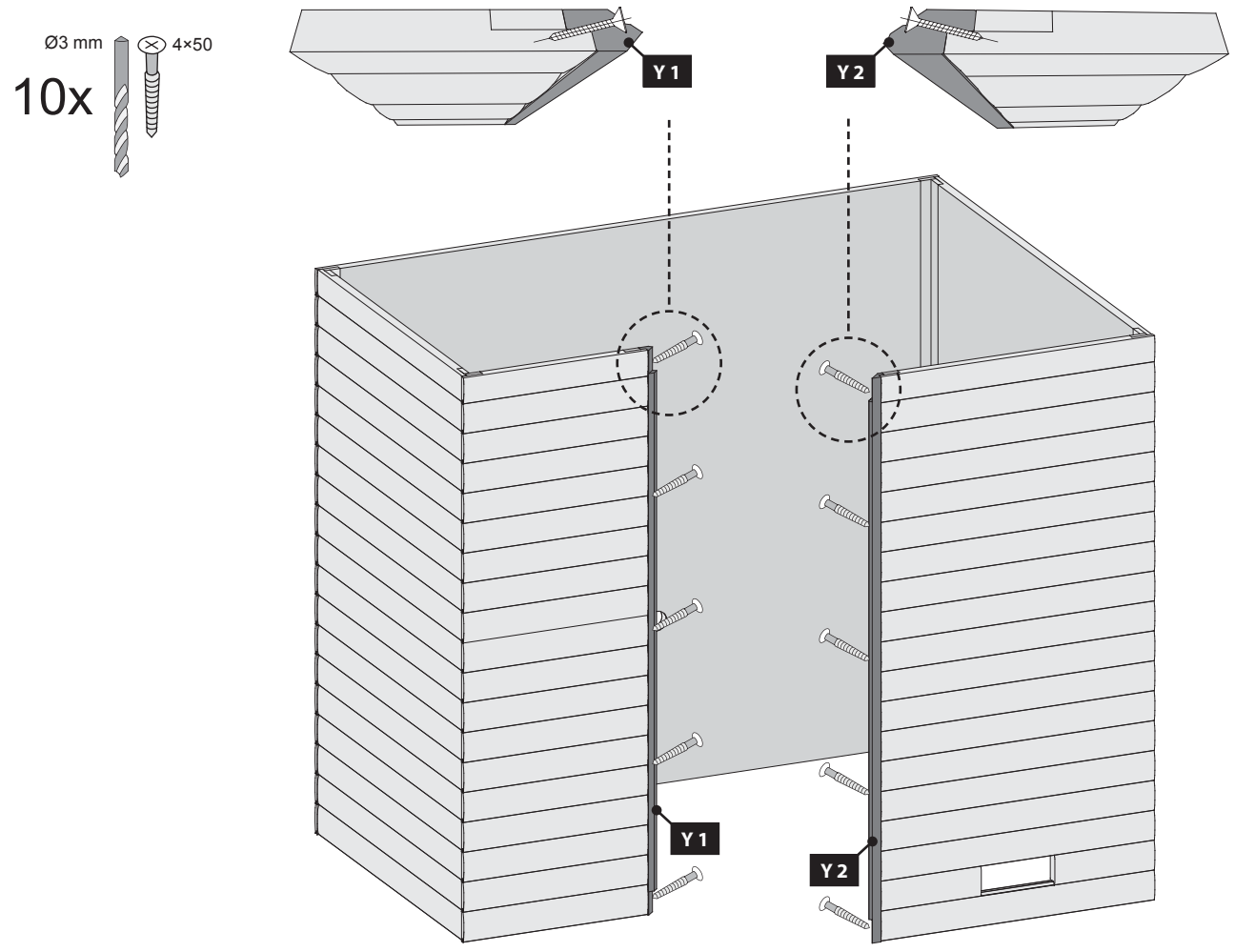
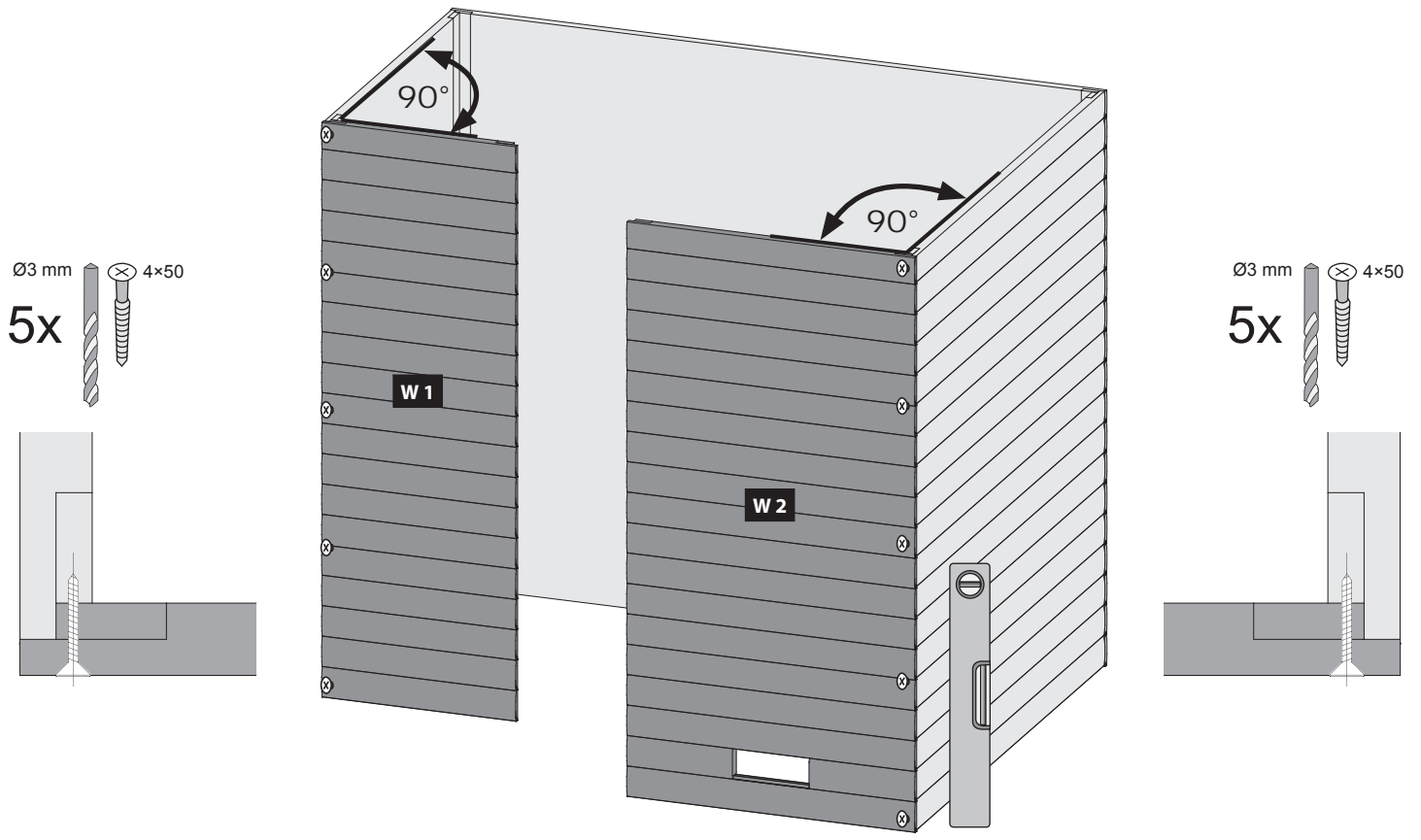

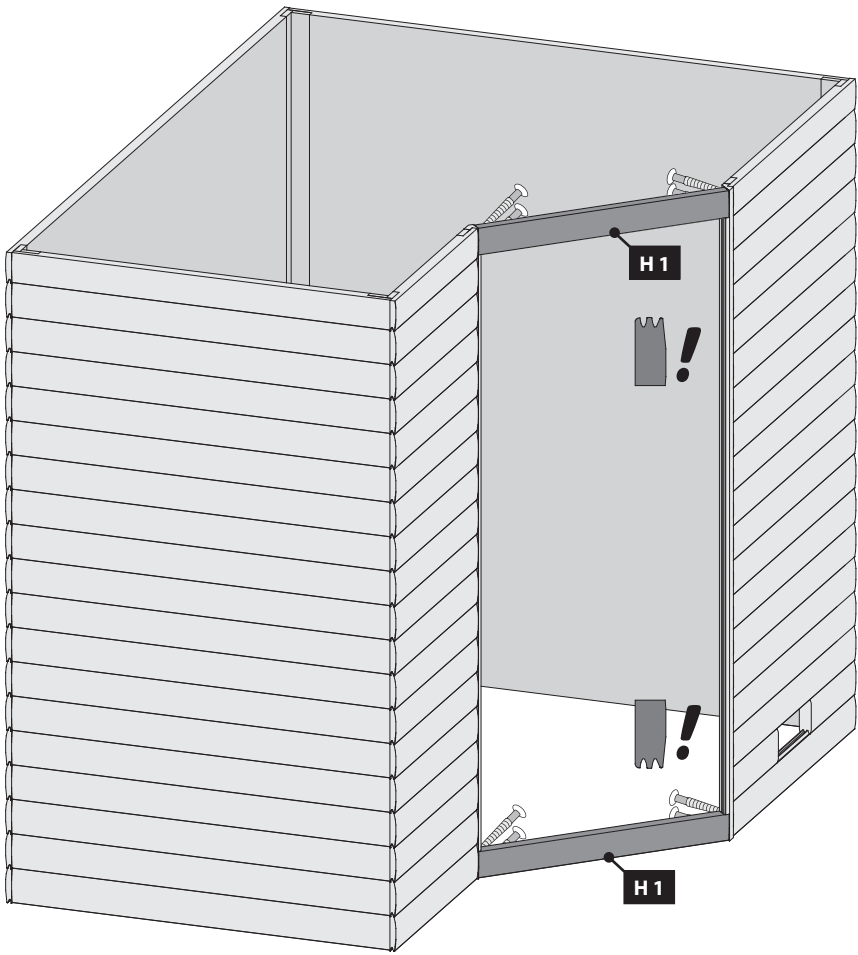

Ø3 mm 4x50
8x

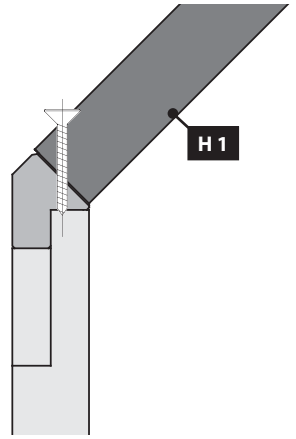

01 — 03

Einbau Saunatur

Installation de porte Sauna

Sauna door installation

Sauna deur installatie

Instalación de la puerta Sauna

Installazione porta Sauna

Sauna Instalace dveře

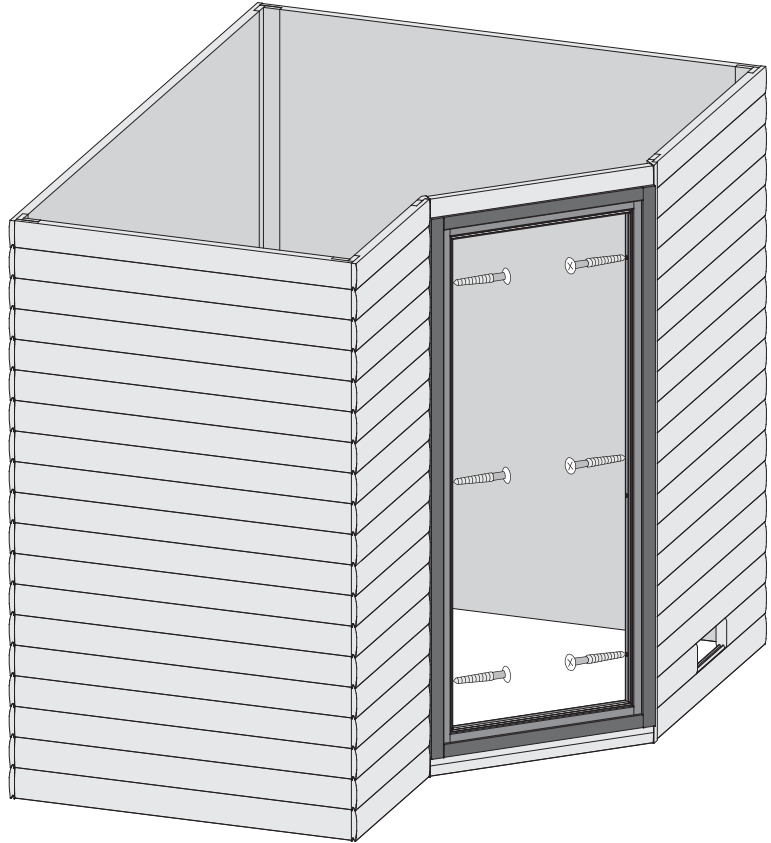

6x 6x80

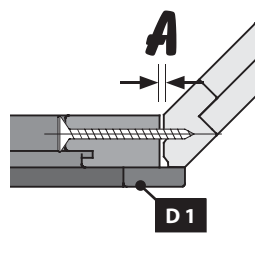
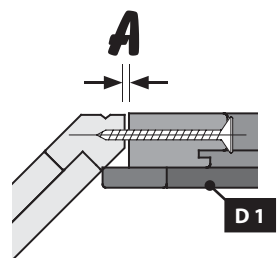
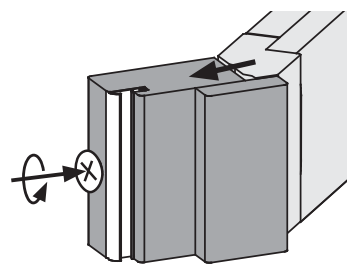
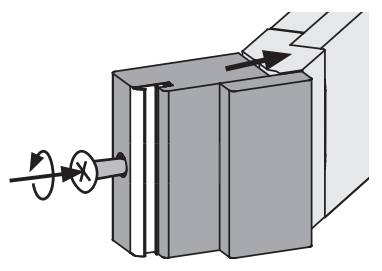

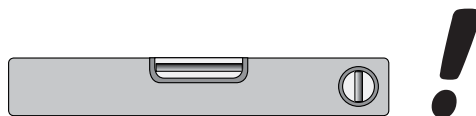
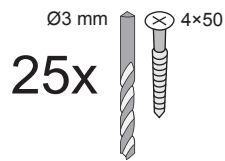
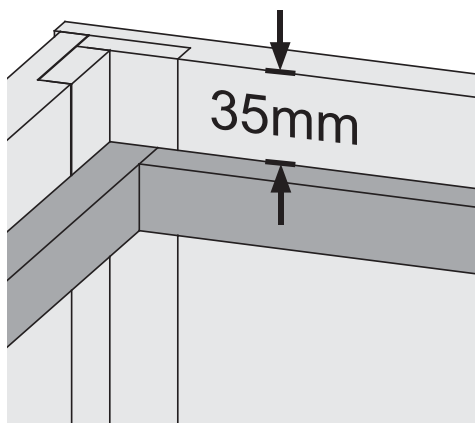
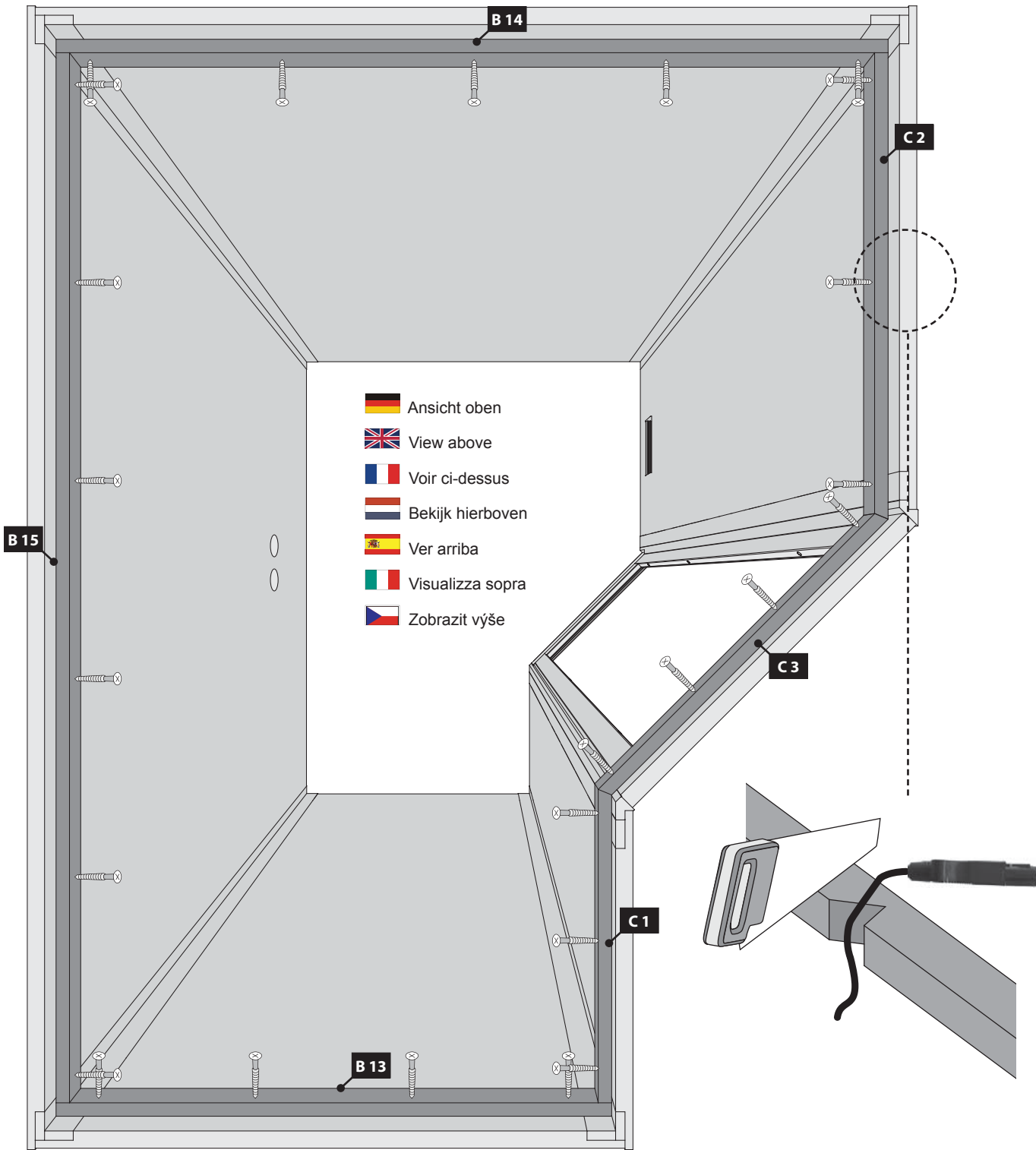

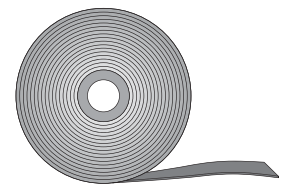
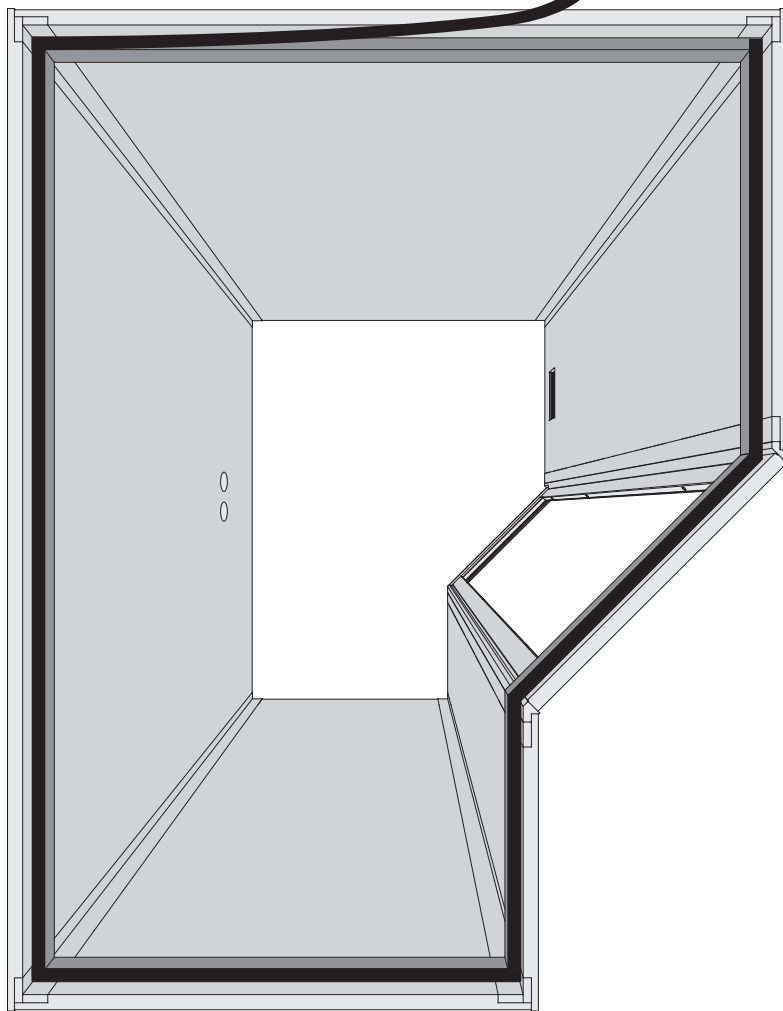



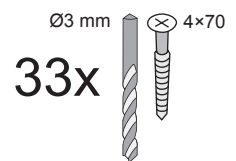
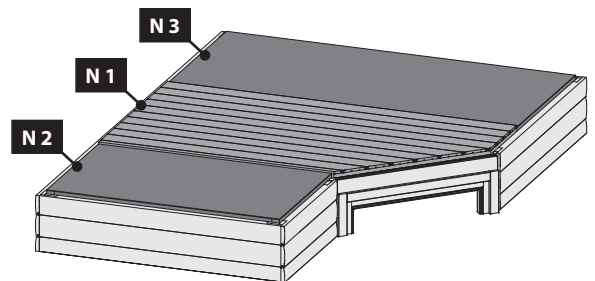
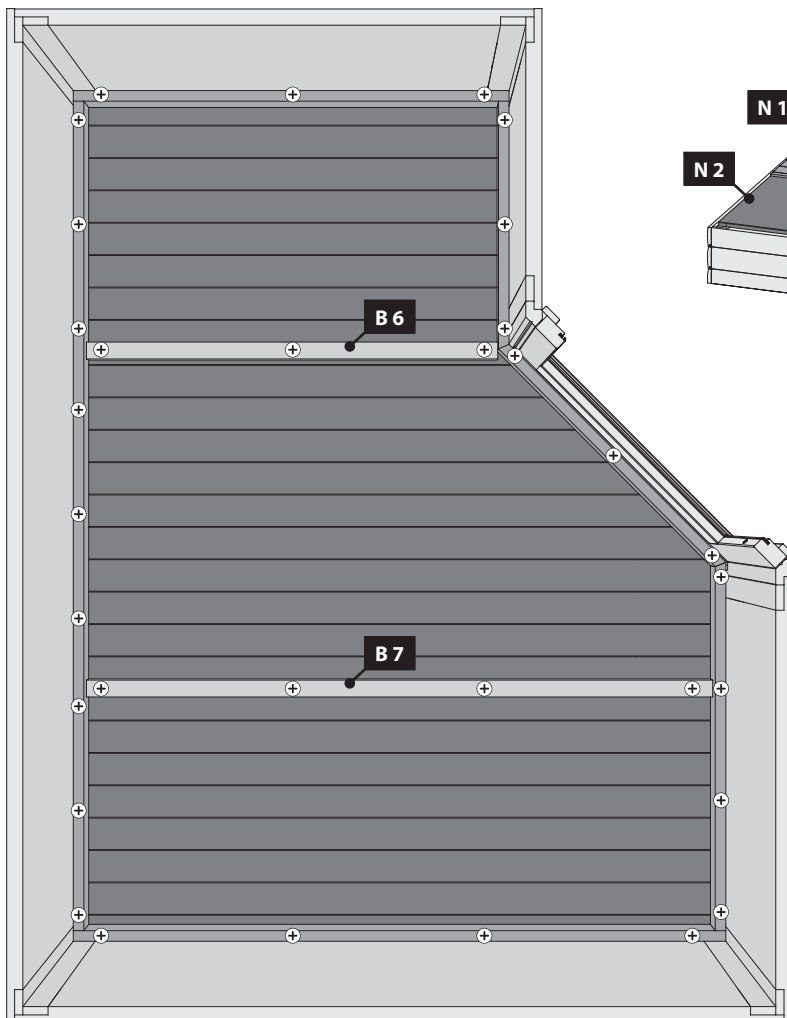



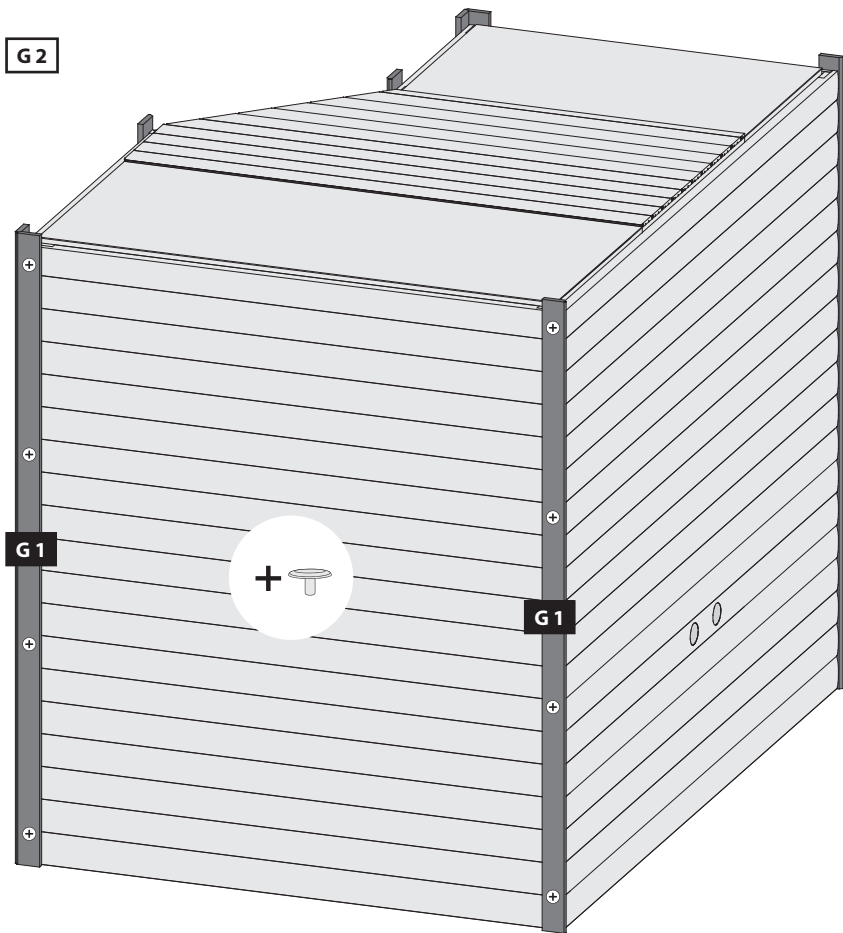
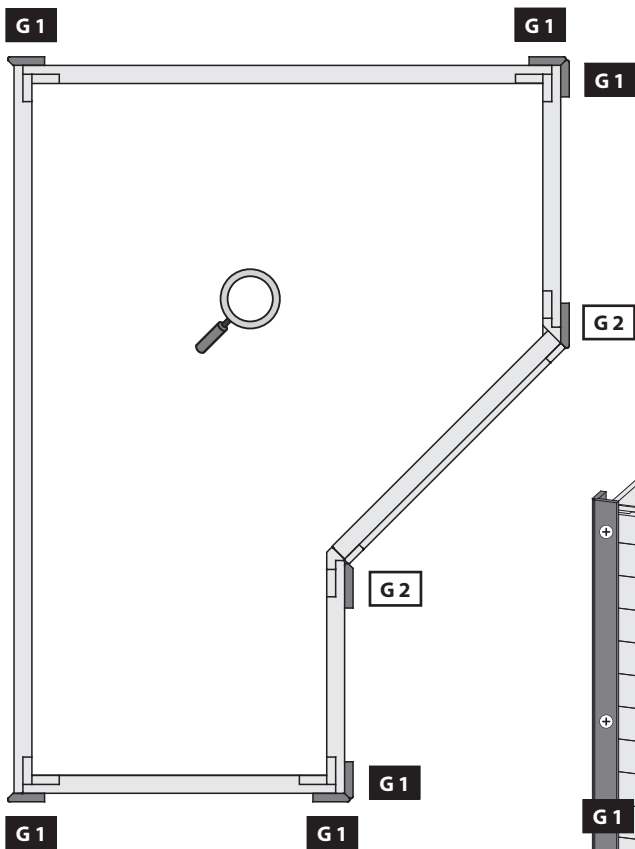
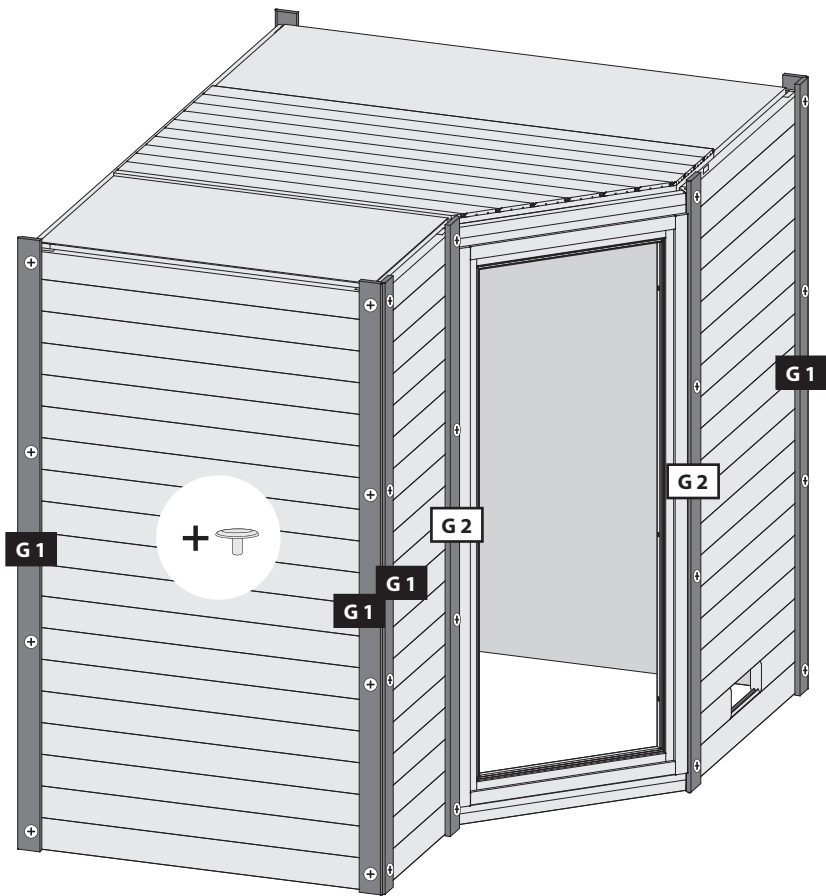

-  Ansicht oben
-  View above
-  Voir ci-dessus
-  Bekijk hierboven
-  Ver arriba
-  Visualizza sopra
-  Zobrazit výše



-  Ansicht unten
-  View below
-  Voir ci-dessous
-  Bekijk hieronder
-  Ver debajo
-  Visualizza sotto
-  Zobrazit níže

Ø3 mm
32x
4,5x40



-  Bündig!
-  Flush!
-  Affleurement!
-  Gelijk!
-  I flugt!
-  Aras!
-  Combacia!
-  Stejný !

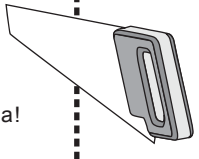

Ø3 mm
17x
4,5x40

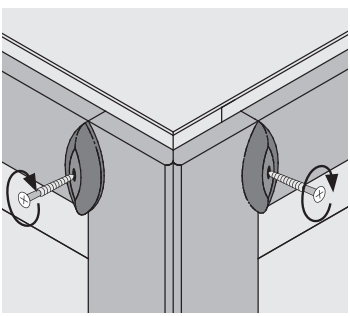
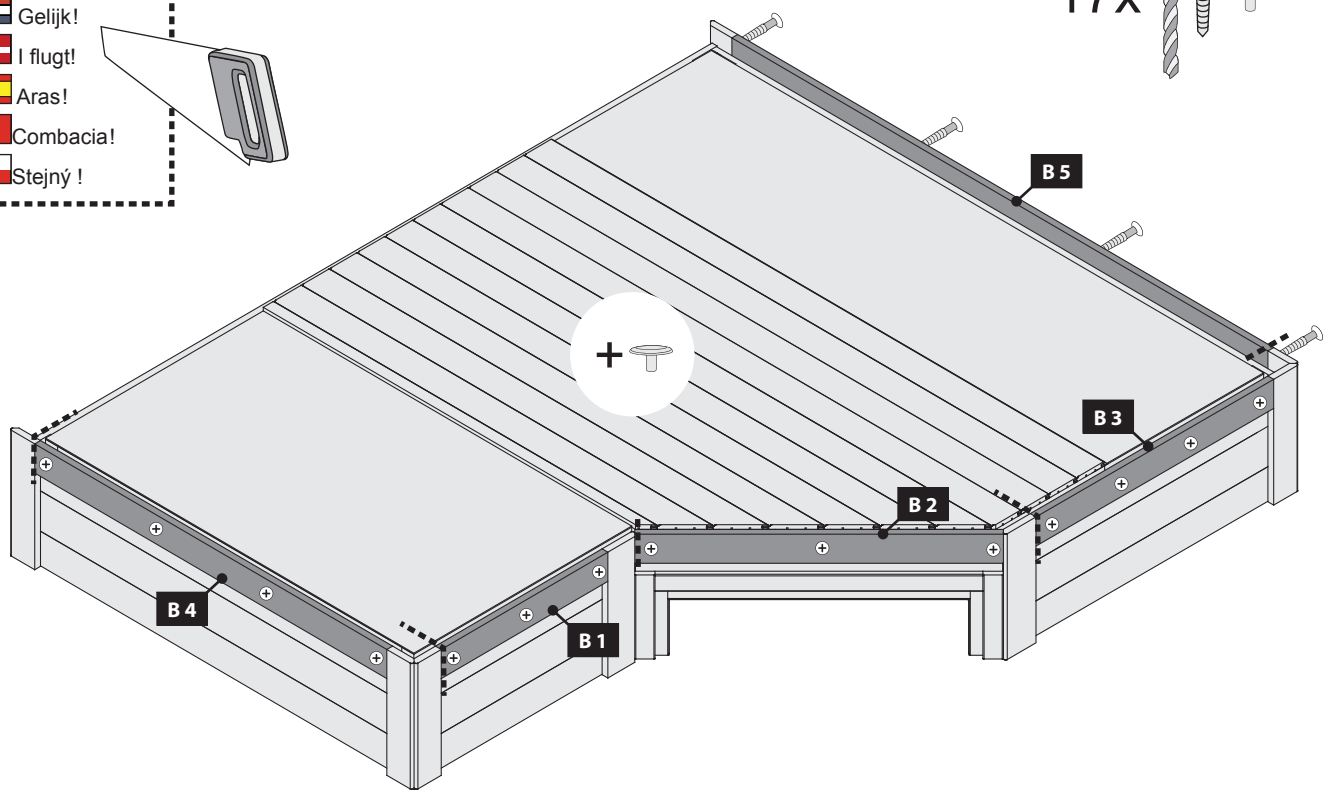

Ø3 mm
8x
4,5x40

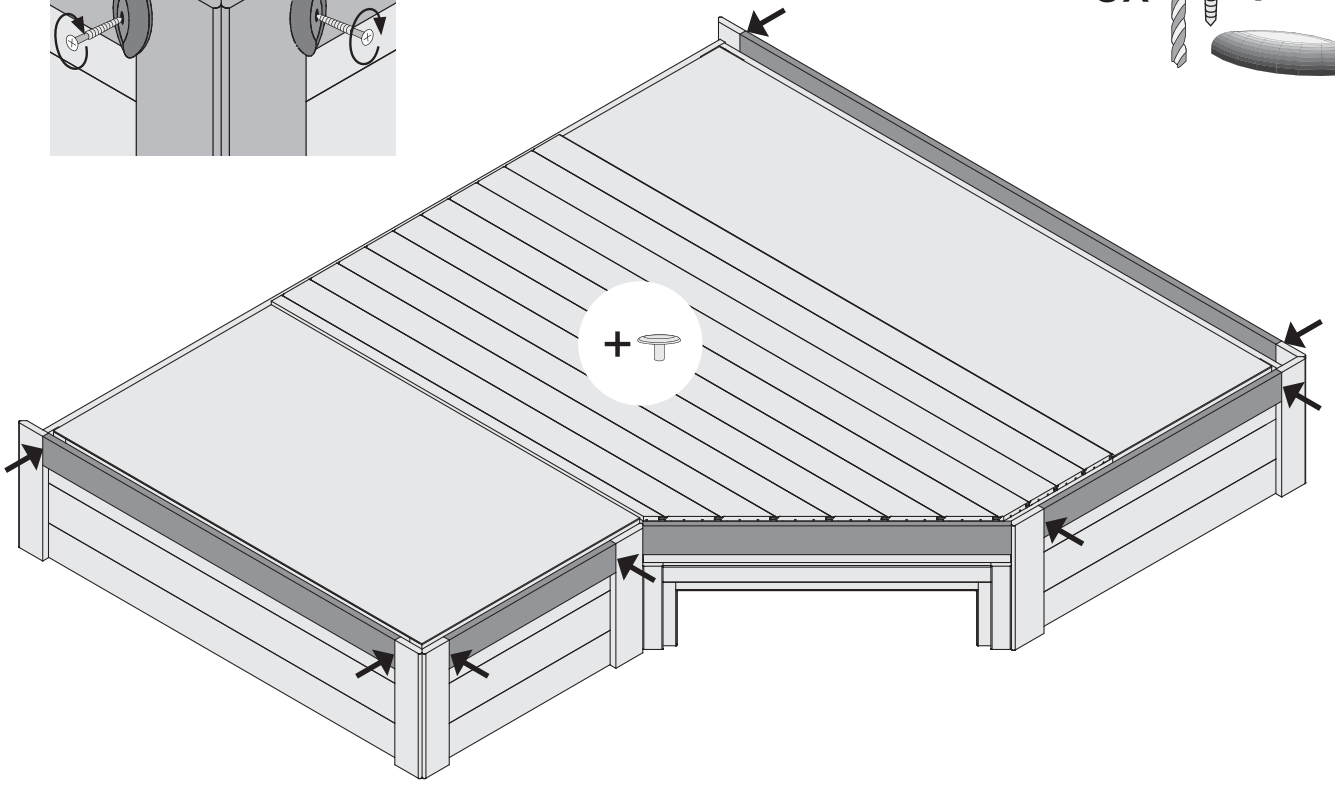

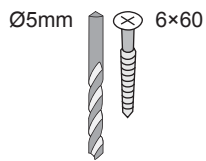

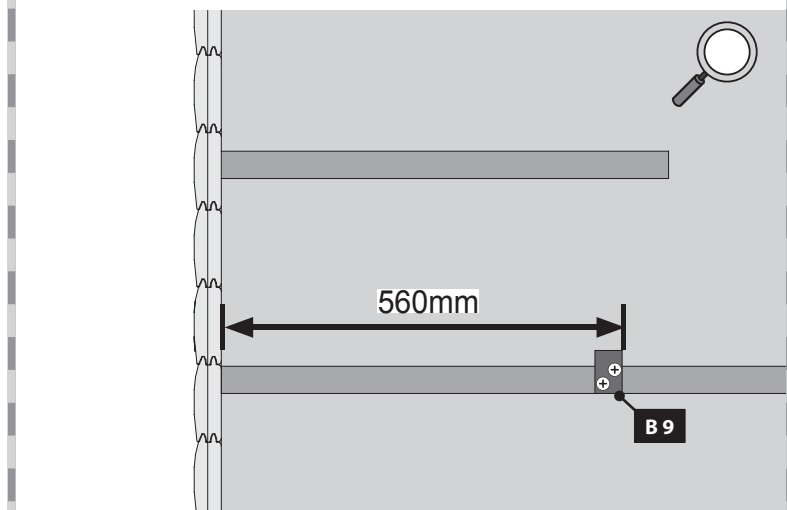
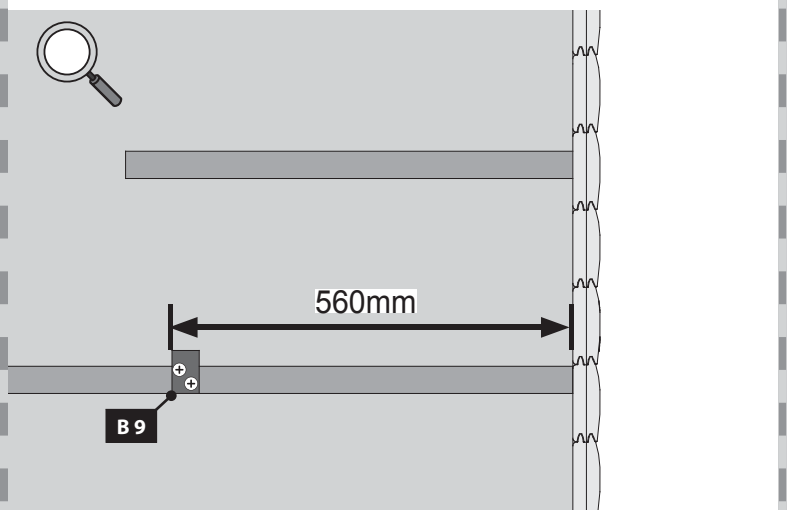
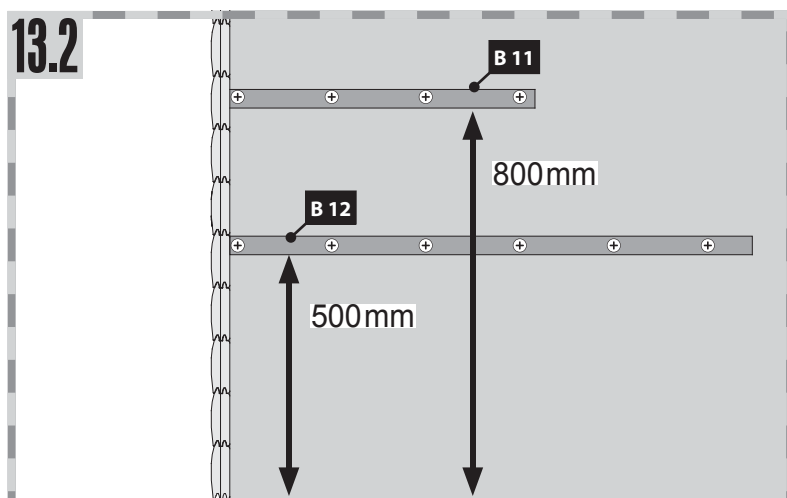
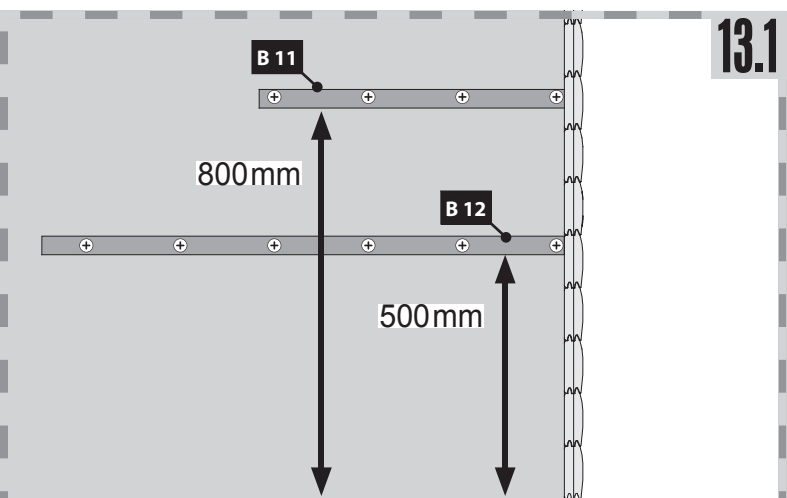
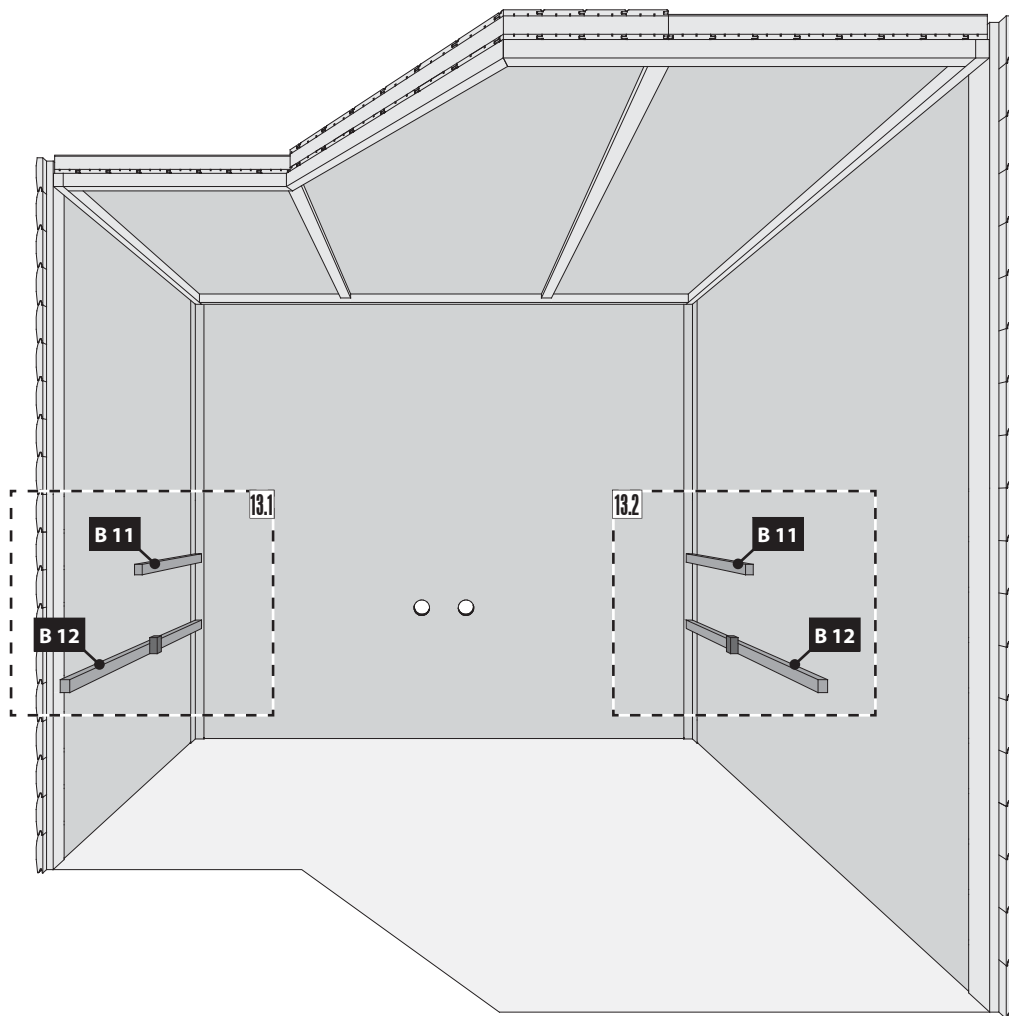

-  Ansicht innen
-  View Inside
-  Voir à l'intérieur
-  Bekijk binnen
-  Ver dentro
-  Visualizza dentro
-  Zobrazit uvnitř

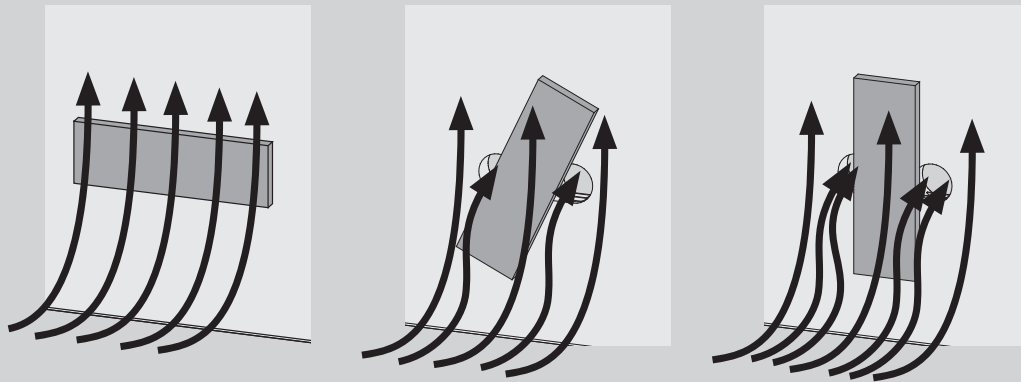
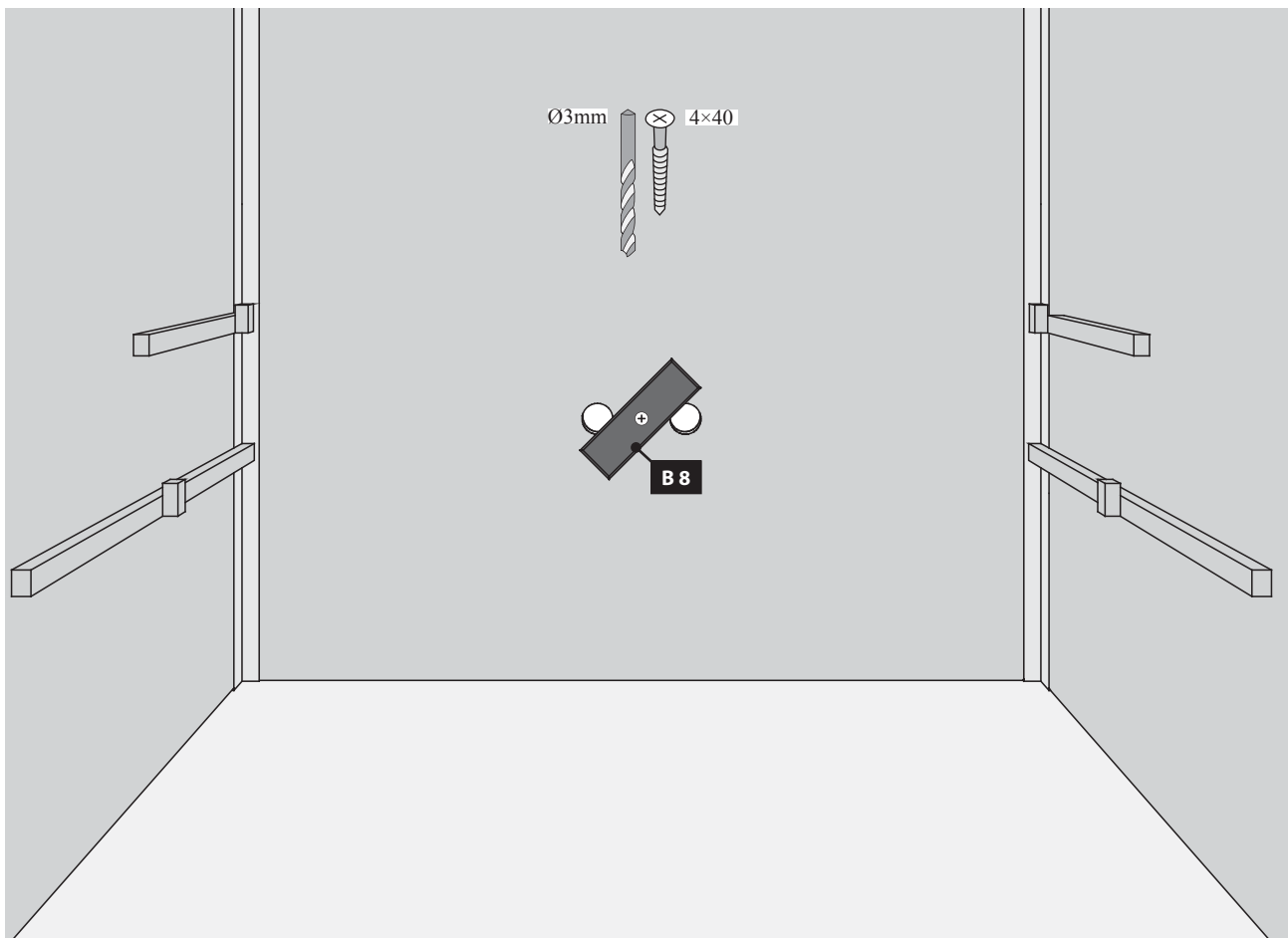



 Hier ist die Funktionsweise des Brettes abgebildet. Regeln Sie damit die Abluft nach Ihren eigenen Wünschen.

 This figure shows the functional principle of the board. Regulate the exhaust air according to your own wishes.

 Hier is de werking van het plankje afgebeeld. Regel daarmee de luchtafvoer naar eigen wens.

 Ceci représente le mode de fonctionnement de la planche. Avec elle, réglez l'écoulement de l'air selon vos désirs.

 Aquí está representada la forma de funcionamiento de la tabla. Regule con ello el aire de salida según sus propios deseos.

 Viene illustrato il principio di funzionamento della tavoletta di regolazione della ventilazione. Con essa si può regolare a piacere la ventilazione.

 Zde je zobrazená funkce desky. Regulujte s ní odsávací vzduch dle Vašeho přání.

15

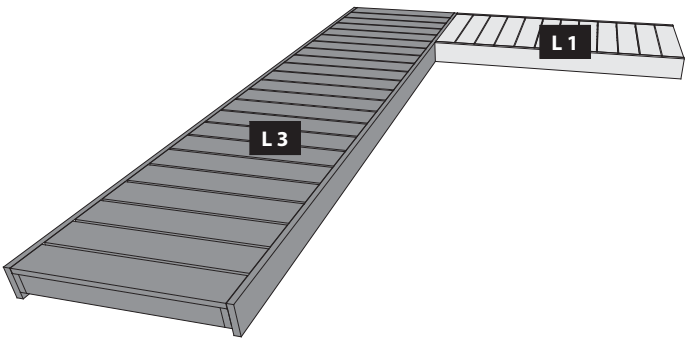

16

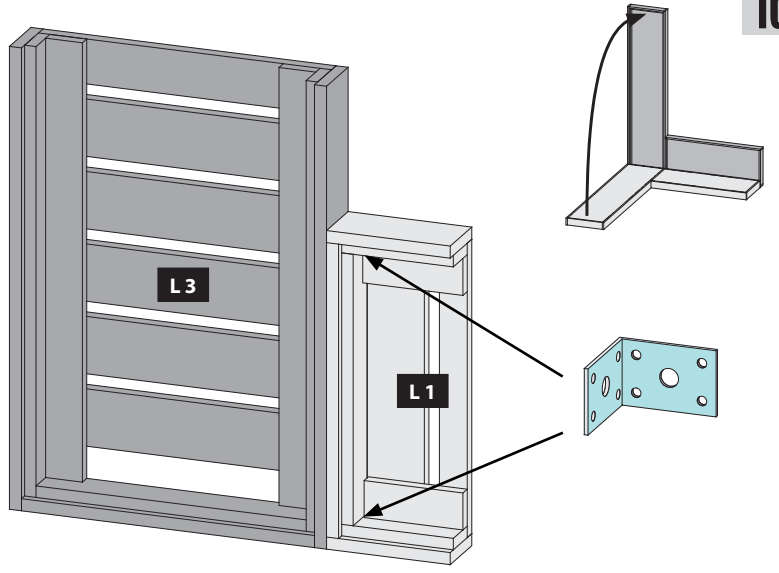

17

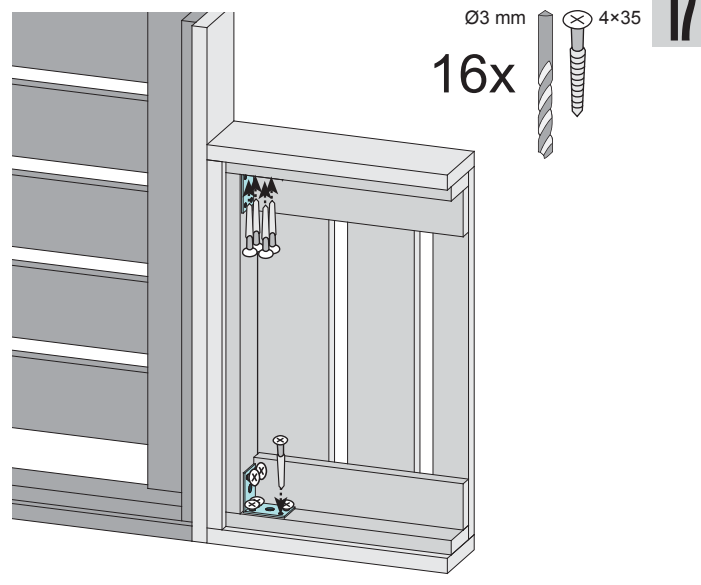

18

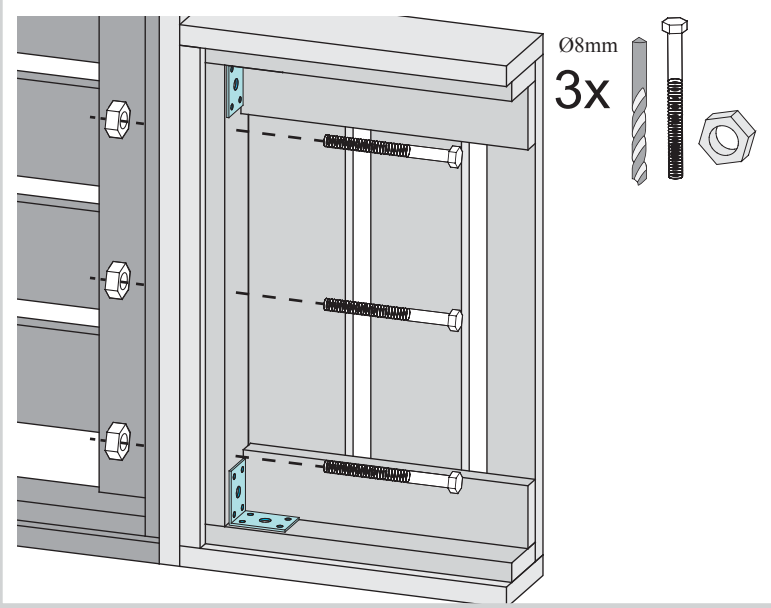

19

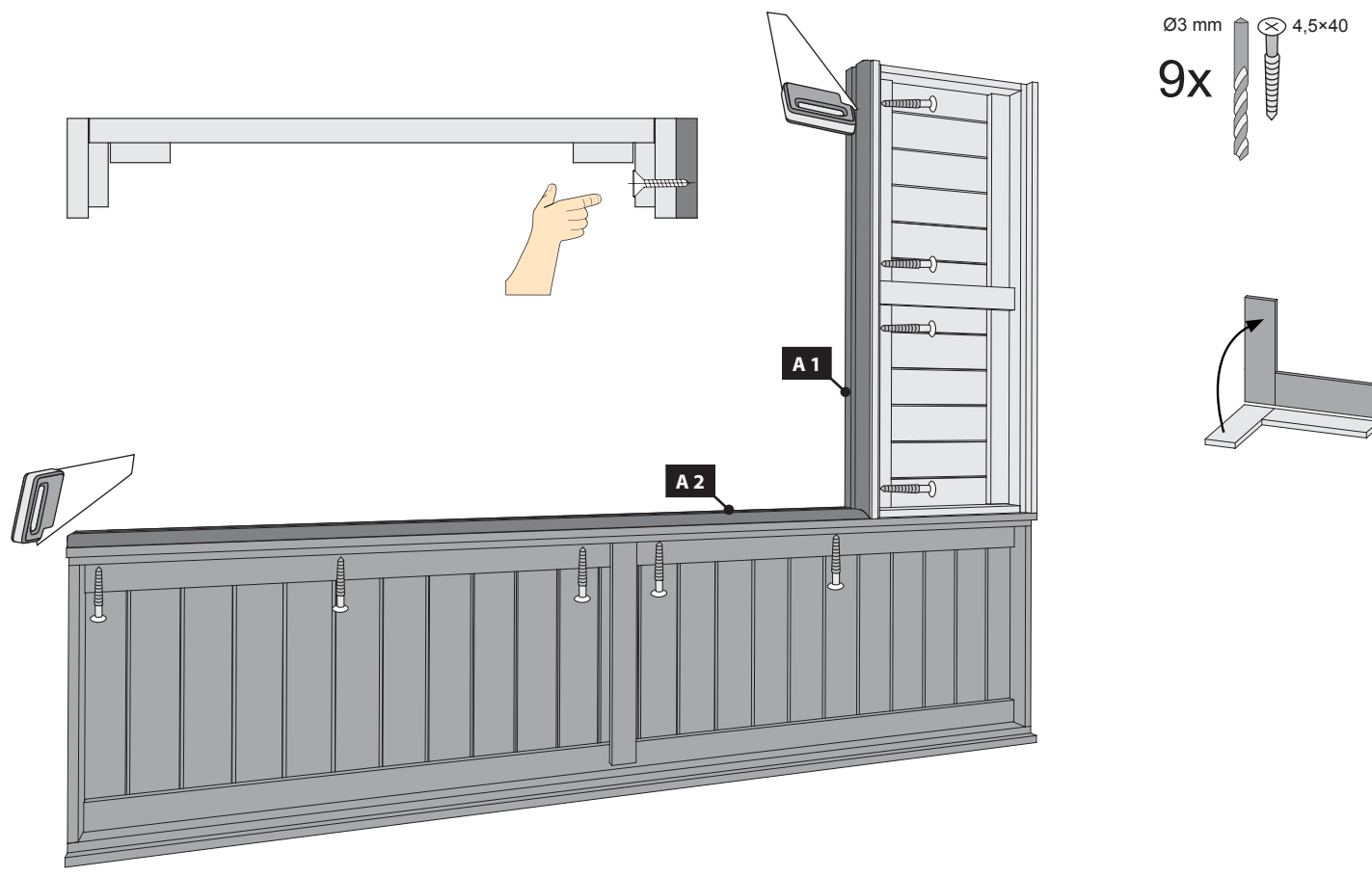

Ø3 mm
5x
4,5x40

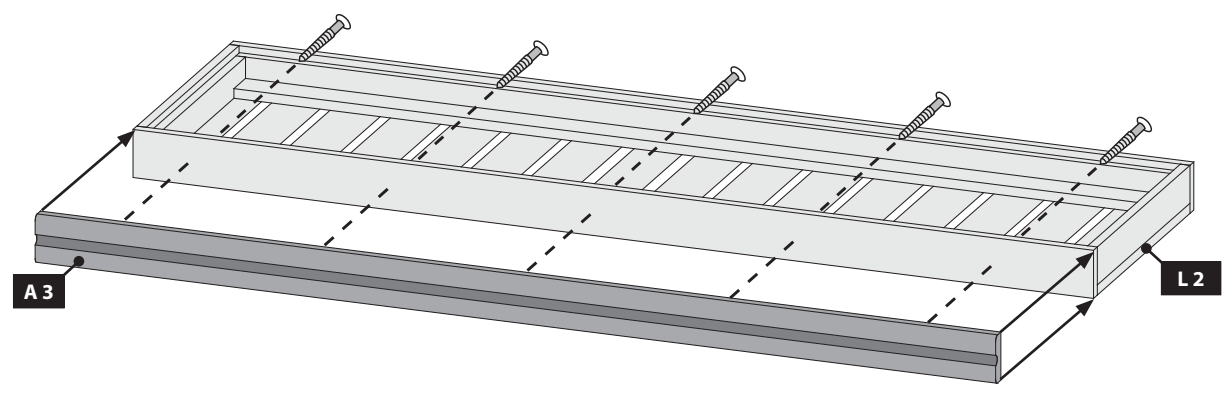
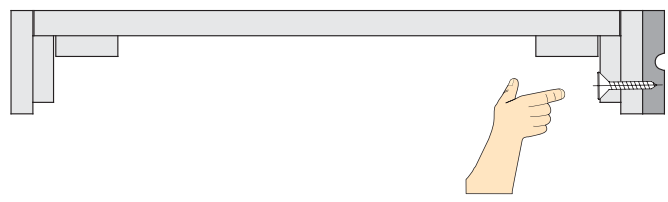

Ø5mm
4x
6x60

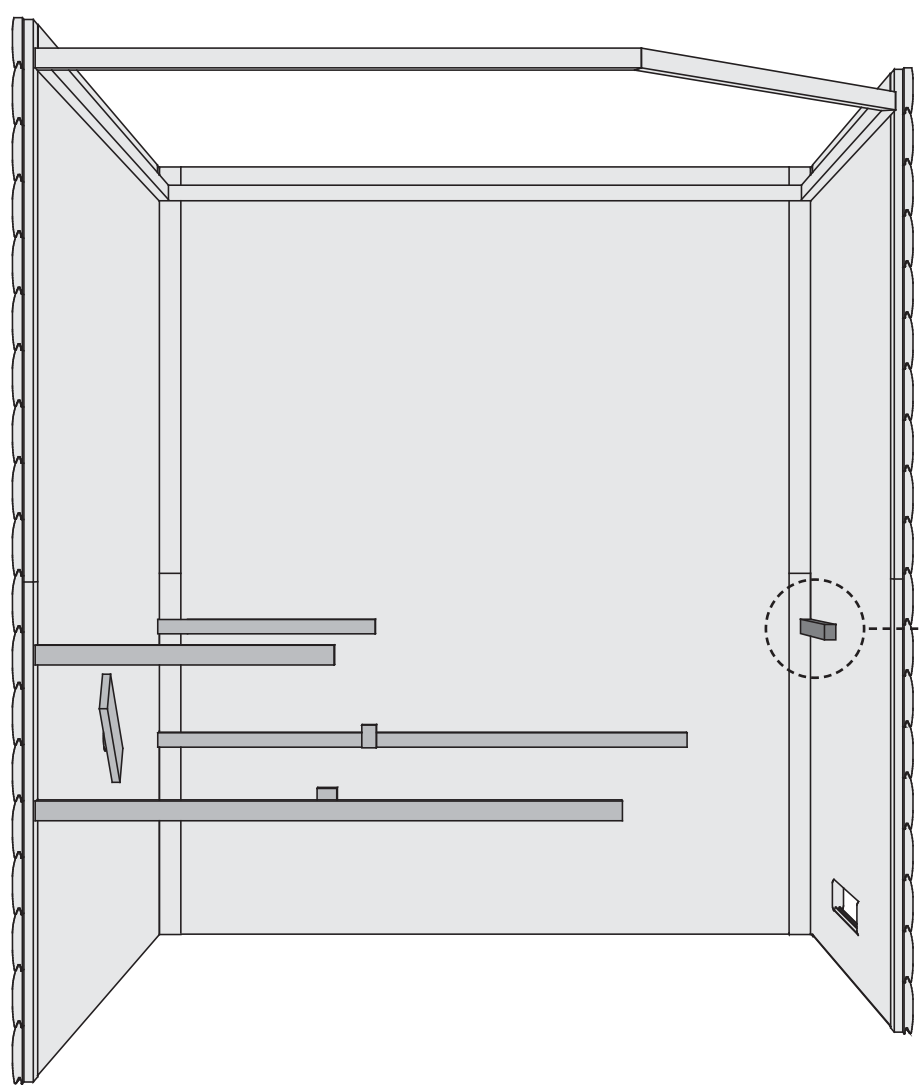

-  Ansicht innen
-  View Inside
-  Voir à l'intérieur
-  Bekijk binnen
-  Ver dentro
-  Visualizza dentro
-  Zobrazit uvnitř

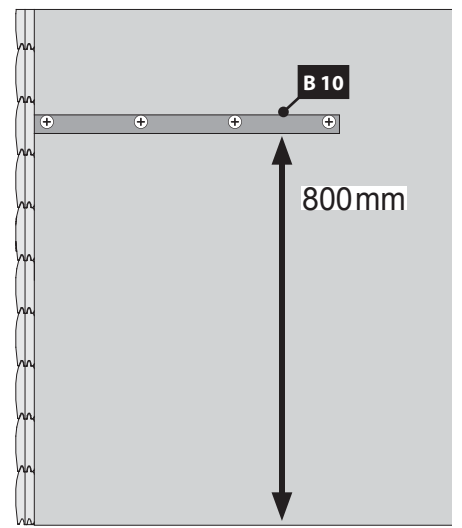
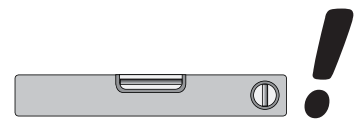

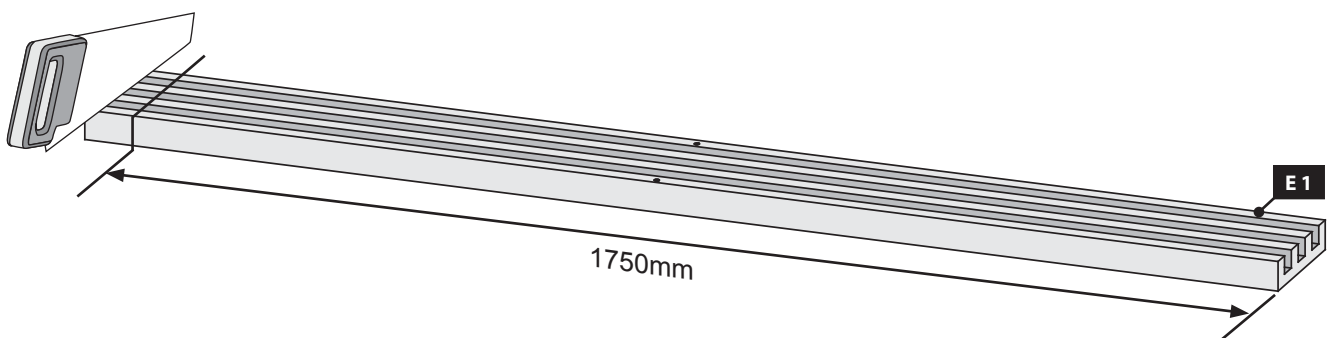
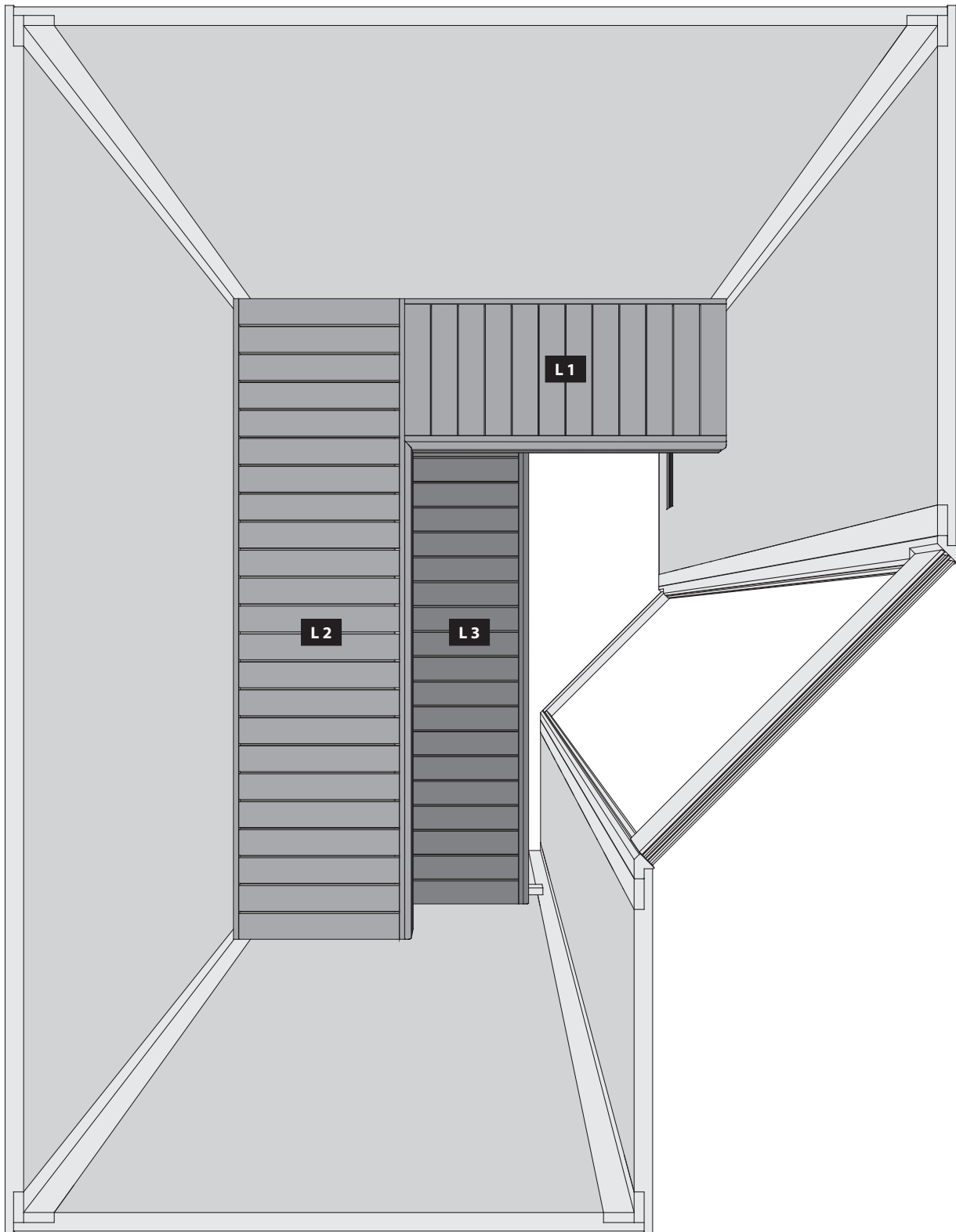

24 a

-  Nur bei 9 kW-Ofen
-  Seulement 9 kW chauffe
-  Only 9 kW heater
-  Slechts 9 kW heater
-  Sólo calentador de 9 kW
-  Solo riscaldamento 9 kW
-  Pouze topné těleso 9 kW

Ø3 mm 4x50

12x

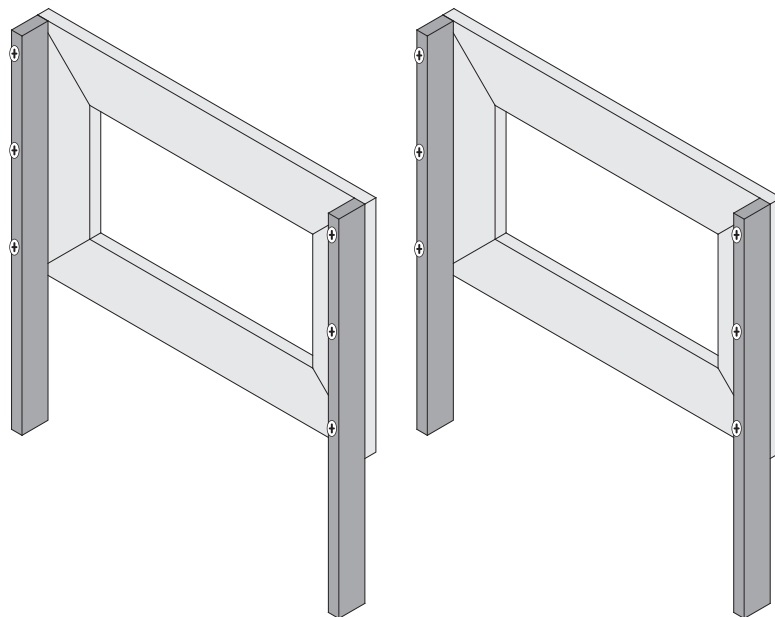
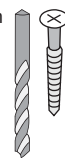

4x

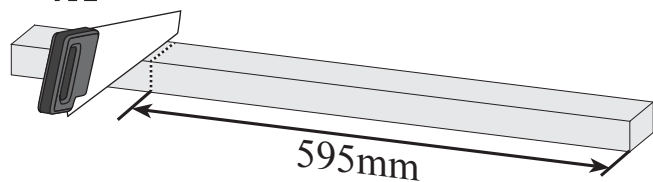

24 b

-  Bei allen anderen Öfen
-  Pour tous les autres fours
-  For all other furnaces
-  Voor alle andere ovens
-  Para todos los otros hornos
-  Per tutti gli altri tipi di forni
-  U všech ostatních pecích

Ø3 mm 4x50

12x

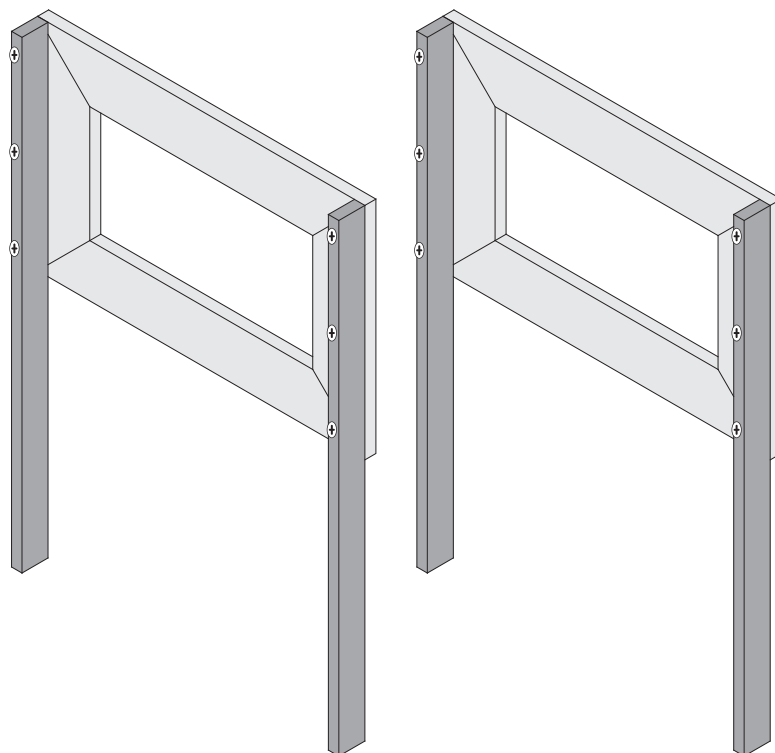
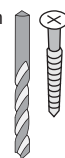

Ø3 mm 4x30

8x

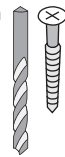
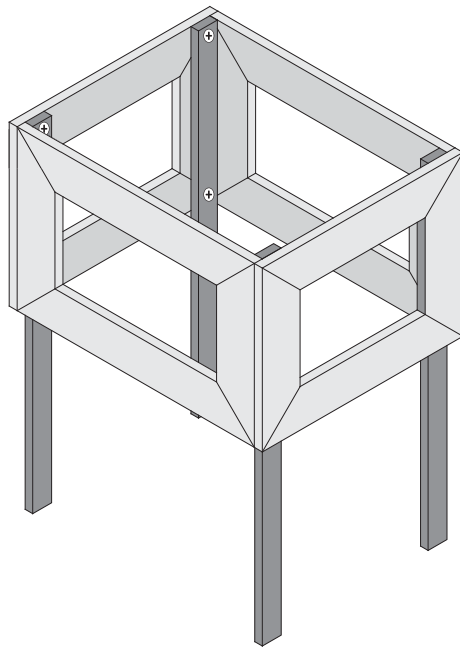

Ø3 mm 4x50

12x

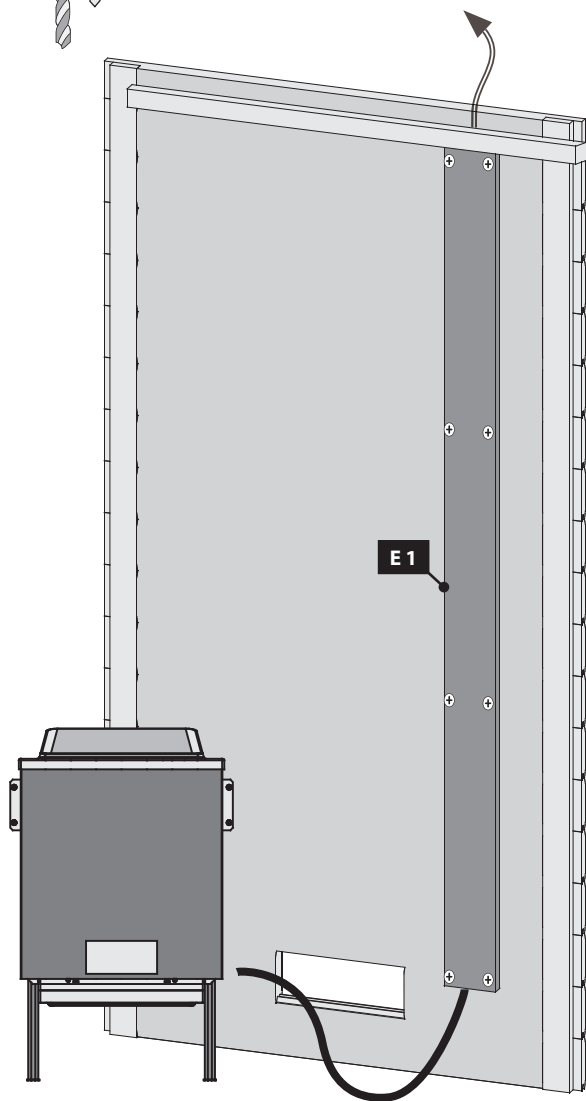
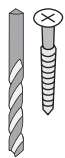

Ø3 mm 4x70

4x

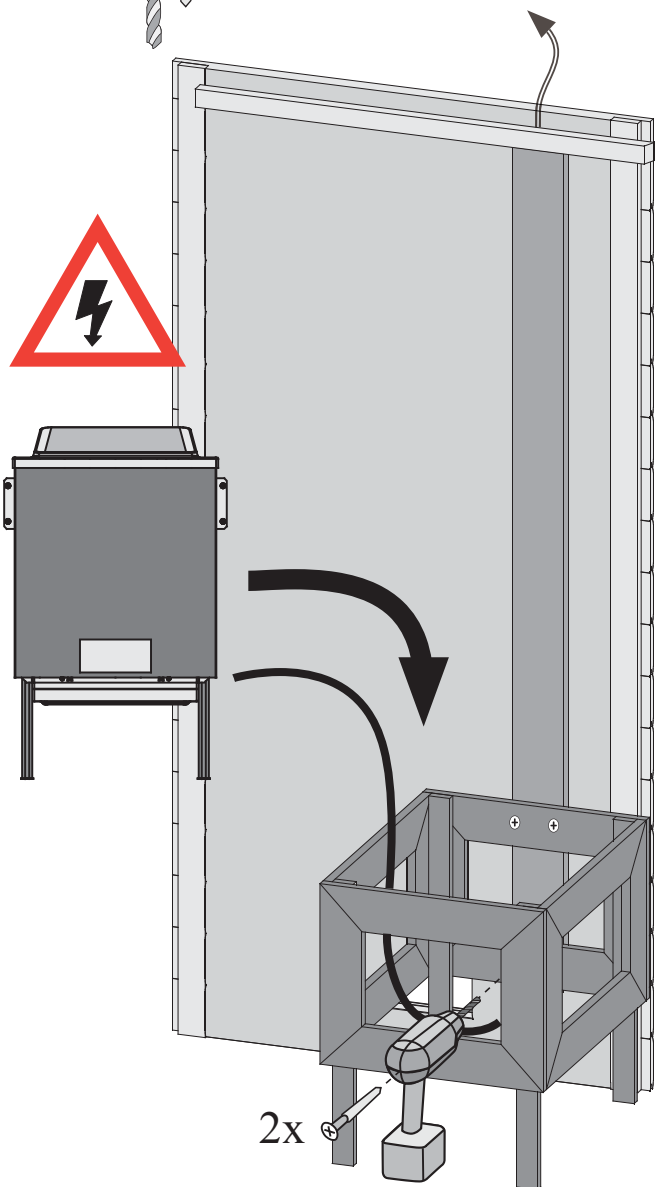
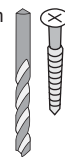



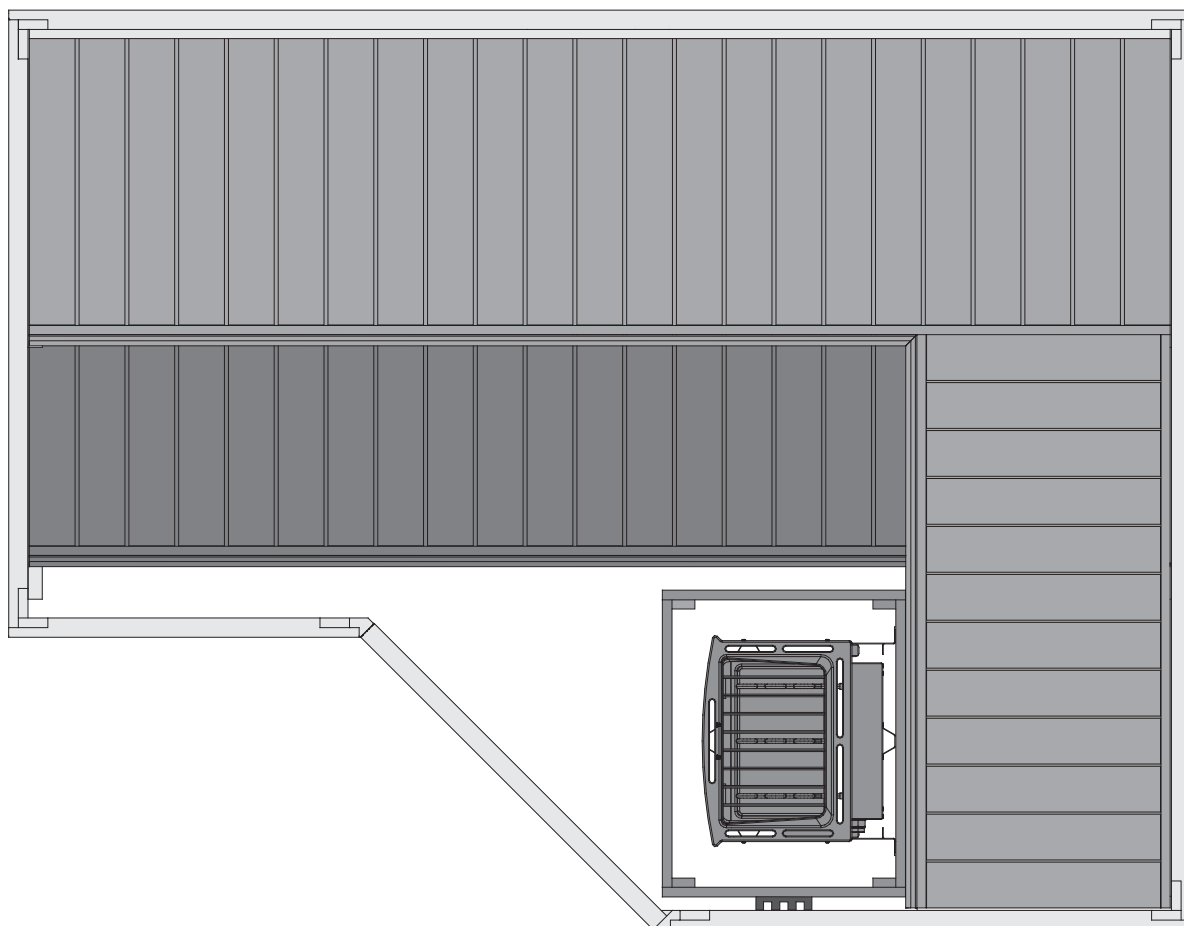
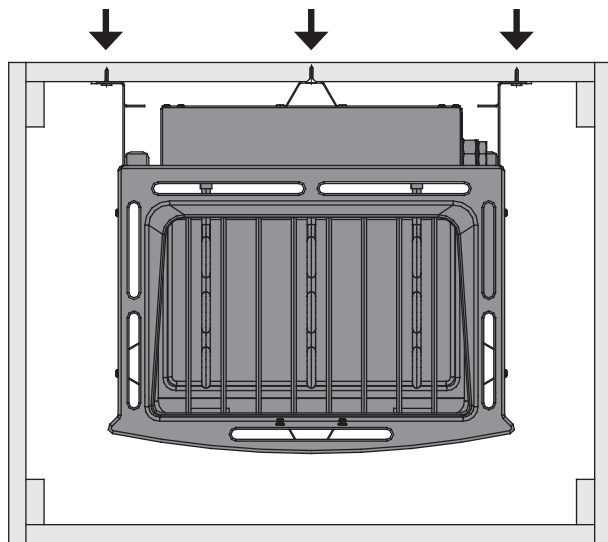
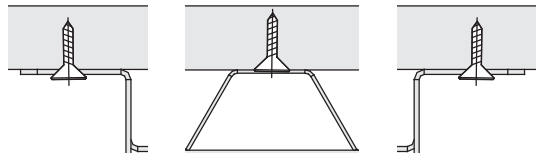



-  Ofenbefestigung
-  oven vaststelling
-  oven fixing
-  fixation four
-  fijación horno
-  fissaggio forno
-  upevňovací trouba



04 — 08



-  Einbau Glastür
-  Installation of glass door
-  Montage porte en verre
-  Montage van de glazen deur

-  Montaje de la puerta de cristal
-  Installazione portello di vetro
-  Namestitev steklena vrata

